



**POMPE FRENO MINISERVO  
POWER BRAKE CYLINDERS**

ADATTABILI MICO  
USED FOR MICO

A  
02

POMPE MINISERVO - POWER CYLINDERS MICO Ø 1" 1/4 - 3/4"		M1	M2
		M3	M4
		<b>Uscita olio - Oil exit</b>	
<b>MS111</b>	Olio freni DOT3-4 - Brake oil DOT3-4		Caterpillar - Hyster

POMPE MINISERVO - POWER CYLINDERS MICO Ø 1" 1/4 - 3/4"		M1	M2
		M3	M4
		<b>Uscita olio - Oil exit</b>	
<b>MS131</b>	Olio freni DOT3-4 - Brake oil DOT3-4		

POMPE MINISERVO - POWER CYLINDERS MICO Ø 1" 1/4 - 3/4"		M1	M2
		M3	M4
		<b>Uscita olio - Oil exit</b>	
<b>MS164</b>	Olio freni DOT3-4 - Brake oil DOT3-4		Caterpillar
<b>MS139</b>	Solo olio minerale - Mineral oil only		Caterpillar





**POMPE FRENO MINISERVO  
POWER BRAKE CYLINDERS**

ADATTABILI MICO  
USED FOR MICO

A  
02

POMPE MINISERVO - POWER CYLINDERS MICO Ø 1" 3/8 - 1" 1/4		M1	M2
		M3	M4
		<b>Uscita olio - Oil exit</b>	
<b>MS151</b>	Olio freni DOT3-4 - Brake oil DOT3-4		Hyster - Caterpillar

POMPE MINISERVO - POWER CYLINDERS MICO		M1	M2
		M3	M4
		<b>Uscita olio - Oil exit</b>	
<b>MS146</b>	Servofreno idraulico - Hydraulic servo brake		Fiat Allis - Caterpillar

POMPE MINISERVO - POWER CYLINDERS MICO Ø 1" 3/4 - 1"		M1	M2
		M3	M4
		<b>Uscita olio - Oil exit</b>	
<b>MS114</b>	Olio freni DOT3-4 - Brake oil DOT3-4		Hyster



I nostri ricambi non sono originali ma con essi perfettamente intercambiabili  
Our spare parts are not original but with them perfectly interchangeable



**POMPE FRENO MINISERVO  
POWER BRAKE CYLINDERS**

ADATTABILI MICO  
USED FOR MICO

A  
02

POMPE MINISERVO - POWER CYLINDERS MICO Ø 1" 3/4 - 1" 1/4		M1	M2
		M3	M4
		Uscita olio - Oil exit	
<b>MS115</b>	Olio freni DOT3-4 - Brake oil DOT3-4	Caterpillar - Hyster	

POMPE MINISERVO - POWER CYLINDERS MICO Ø 1" 3/4 - 1"		M1	M2
		M3	M4
		Uscita olio - Oil exit	
<b>MS179M</b>	Solo olio minerale - Mineral oil only	Caterpillar	

POMPE MINISERVO - POWER CYLINDERS MICO Ø 1" 3/8 - 1" 7/8		M1	M2
		M3	M4
		Uscita olio - Oil exit	
<b>MS112</b>	Olio freni DOT3-4 - Brake oil DOT3-4	Hyster - Clark	





**POMPE FRENO MINISERVO  
POWER BRAKE CYLINDERS**

ADATTABILI MICO  
USED FOR MICO

A  
02

POMPE MINISERVO - POWER CYLINDERS MICO Ø 1" 1/4 - 1" 11/64"		M1	M2
		M3	M4
		Uscita olio - Oil exit	
		<b>MS113</b> Olio freni DOT3-4 - Brake oil DOT3-4                      Clark	

POMPE MINISERVO - POWER CYLINDERS MICO Ø 1" 3/4 - 1"		M1	M2
		M3	M4
		Uscita olio - Oil exit	
		<b>MS120</b> Olio freni DOT3-4 - Brake oil DOT3-4                      Clark - International	

POMPE MINISERVO - POWER CYLINDERS MICO Ø 1" 3/4 - 1" 1/4		M1	M2
		M3	M4
		Uscita olio - Oil exit	
		<b>MS181</b> Olio freni DOT3-4 - Brake oil DOT3-4                      Clark - International	



I nostri ricambi non sono originali ma con essi perfettamente intercambiabili  
Our spare parts are not original but with them perfectly interchangeable



**POMPE FRENO MINISERVO  
POWER BRAKE CYLINDERS**

ADATTABILI MICO  
USED FOR MICO

A  
02

**POMPE MINISERVO - POWER CYLINDERS MICO Ø 1" 1/8 - 28.57**

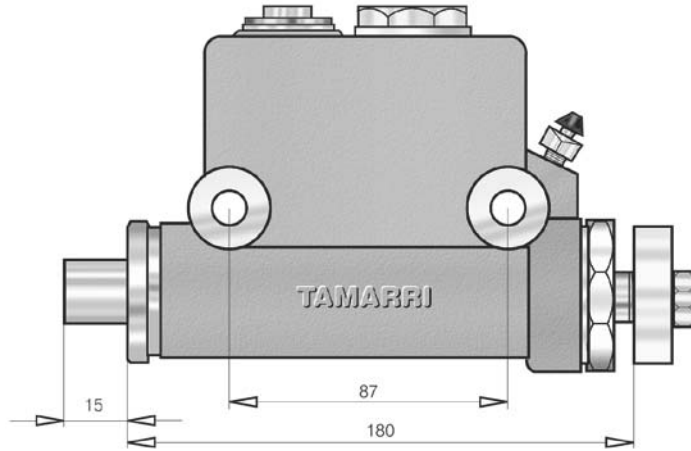
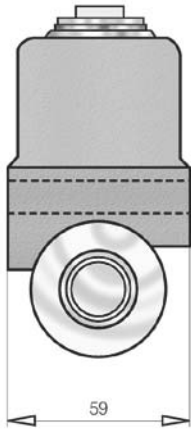

**MS125**

Olio freni DOT3-4 - Brake oil DOT3-4

Caterpillar - Clark

M1

M2

M3

M4

Uscita olio - Oil exit

**POMPE MINISERVO - POWER CYLINDERS MICO Ø 1" 1/8 - 1" 1/2**

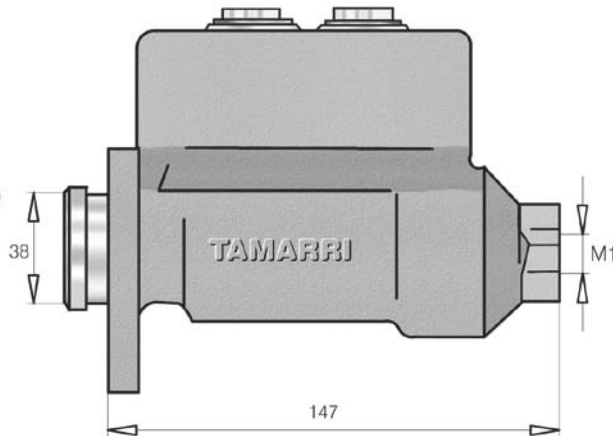
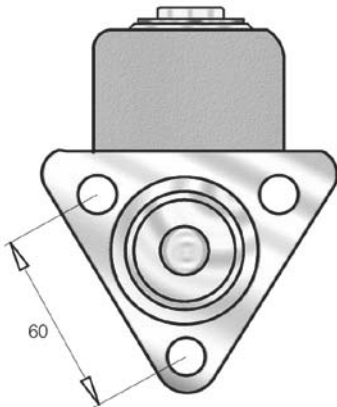

**MS121**

Olio freni DOT3-4 - Brake oil DOT3-4

Clark

M1

M2

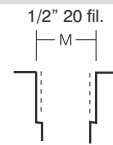

M3

M4

Uscita olio - Oil exit

**POMPE MINISERVO - POWER CYLINDERS MICO Ø 1" 1/2 - 7/8"**

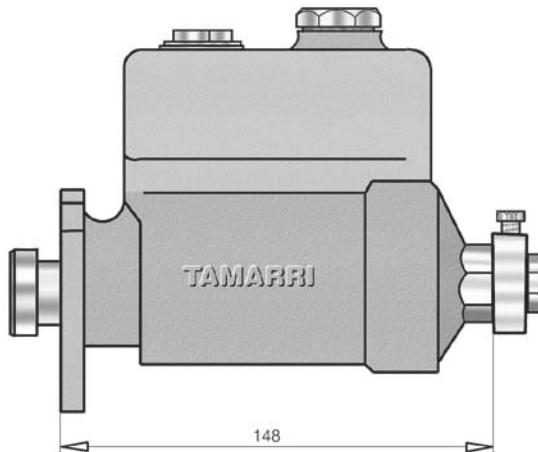
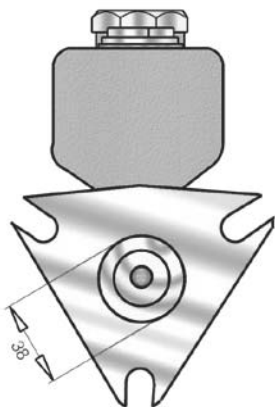

**MS152**

Olio freni DOT3-4 - Brake oil DOT3-4

Clark

M1

M2

M3

M4

Uscita olio - Oil exit



I nostri ricambi non sono originali ma con essi perfettamente intercambiabili  
Our spare parts are not original but with them perfectly interchangeable



**POMPE FRENO MINISERVO  
POWER BRAKE CYLINDERS**

ADATTABILI MICO  
USED FOR MICO

A  
02

POMPE MINISERVO - POWER CYLINDERS MICO		M1	M2
		M3	M4
		Uscita olio - Oil exit	
<b>MS154</b>	Con servofreno ad aria - With air servo brake	International	

POMPE MINISERVO - POWER CYLINDERS MICO Ø 1"		M1	M2
		M3	M4
		Uscita olio - Oil exit	
<b>MS161</b>	Solo olio minerale - Mineral oil only	Daewoo - Caterpillar	

POMPE MINISERVO - POWER CYLINDERS MICO Ø 1 1/8		M1	M2
		M3	M4
		Uscita olio - Oil exit	
<b>MS162</b>	Solo olio minerale - Mineral oil only	Daewoo - Caterpillar	



I nostri ricambi non sono originali ma con essi perfettamente intercambiabili  
Our spare parts are not original but with them perfectly interchangeable



**POMPE FRENO MINISERVO  
POWER BRAKE CYLINDERS**

ADATTABILI MICO  
USED FOR MICO

A  
02

POMPE MINISERVO - POWER CYLINDERS MICO		M1	M2
		3/4" UNF 16 G	1" 1/16 12 G
		M3	M4
		Uscita olio - Oil exit	
<b>MS132</b>	Olio freni DOT3-4 - Brake oil DOT3-4	Hyster	

POMPE MINISERVO - POWER CYLINDERS MICO 1" 1/2		M1	M2
		1/2" 20 fil. M	1/2" 20 fil. M
		M3	M4
		Uscita olio - Oil exit	
<b>MS182</b>	Olio freni DOT3-4 - Brake oil DOT3-4		

POMPE MINISERVO - POWER CYLINDERS MICO 1" 3/4 - 1" 1/8		M1	M2
		1/2" 20 fil. M	
		M3	M4
		Uscita olio - Oil exit	
<b>MS176</b>	Olio freni DOT3-4 - Brake oil DOT3-4		



I nostri ricambi non sono originali ma con essi perfettamente intercambiabili  
Our spare parts are not original but with them perfectly interchangeable



**POMPE FRENO MINISERVO  
POWER BRAKE CYLINDERS**

ADATTABILI MICO  
USED FOR MICO

A  
02

POMPE MINISERVO - POWER CYLINDERS MICO 1" 1/4 - 1"		M1	M2
		M3	M4
	<b>Uscita olio - Oil exit</b>		
<b>MS180</b>	Olio freni DOT3-4 - Brake oil DOT3-4		

POMPE MINISERVO - POWER CYLINDERS MICO 1" 1/4		M1	M2
		M3	M4
	<b>Uscita olio - Oil exit</b>		
<b>MS186</b>	Olio freni DOT3-4 - Brake oil DOT3-4		

POMPE MINISERVO - POWER CYLINDERS MICO 1" 1/4 - 3/4"		M1	M2
		M3	M4
	<b>Uscita olio - Oil exit</b>		
<b>MS199</b>	Olio freni DOT3-4 - Brake oil DOT3-4		Caterpillar



I nostri ricambi non sono originali ma con essi perfettamente intercambiabili  
Our spare parts are not original but with them perfectly interchangeable





**POMPE FRENO MINISERVO  
POWER BRAKE CYLINDERS**

ADATTABILI MICO  
USED FOR MICO

A  
02

**POMPE MINISERVO - POWER CYLINDERS MICO 1" 1/8 - 2" 1/4**

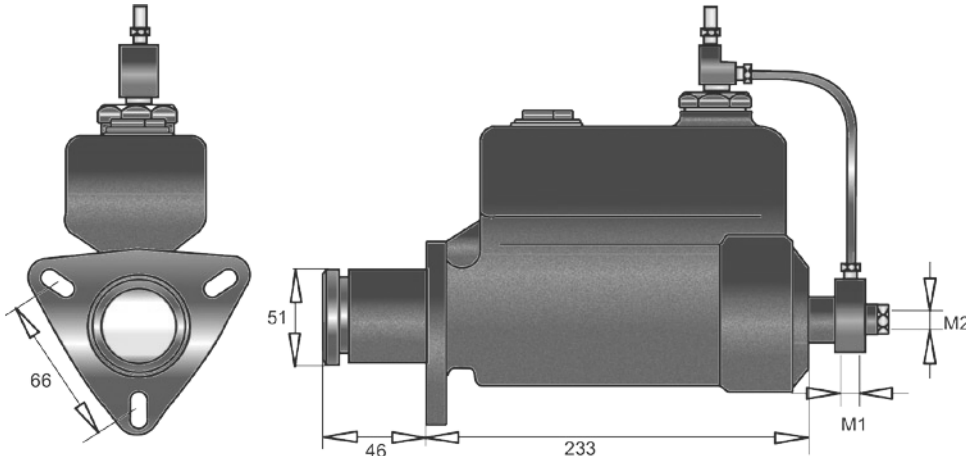

M1	M2
7/16" 24 fil. 	3/8" 24 fil. 
M3	M4
<b>Uscita olio - Oil exit</b>	

**MS221** Olio freni DOT3-4 - Brake oil DOT3-4 Galion

**POMPE MINISERVO - POWER CYLINDERS MICO**

M1	M2
M3	M4
<b>Uscita olio - Oil exit</b>	

**POMPE MINISERVO - POWER CYLINDERS MICO**

M1	M2
M3	M4
<b>Uscita olio - Oil exit</b>	





**POMPE FRENO MINISERVO  
POWER BRAKE CYLINDERS**

ADATTABILI SAFIM  
USED FOR SAFIM

A  
02

**POMPE MINISERVO - POWER CYLINDERS SAFIM**

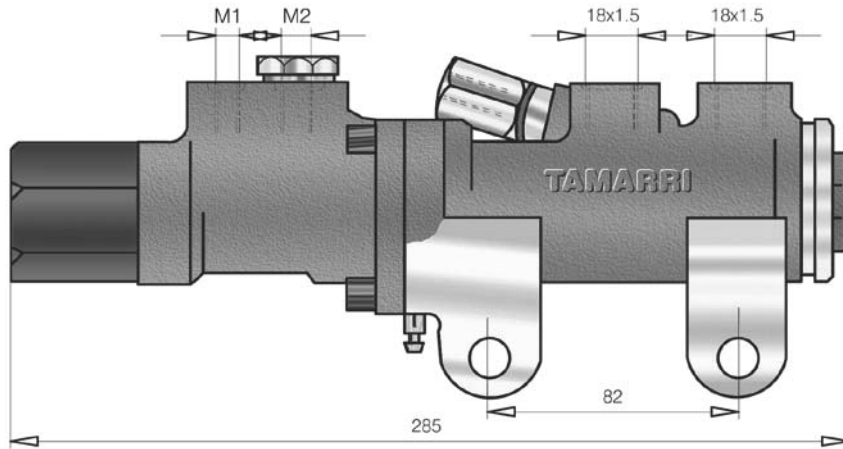

**M1**

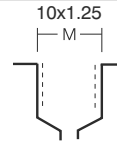

**M2**

Valvola 12x1.5

**M3**

**M4**

**Codici - Codes SAFIM**

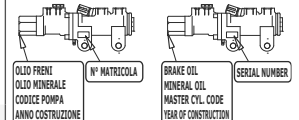

**MS106**

Cilindrata totale 19 cm<sup>3</sup> - Total displacement 19 cm<sup>3</sup>

Cesab

**POMPE MINISERVO - POWER CYLINDERS SAFIM**

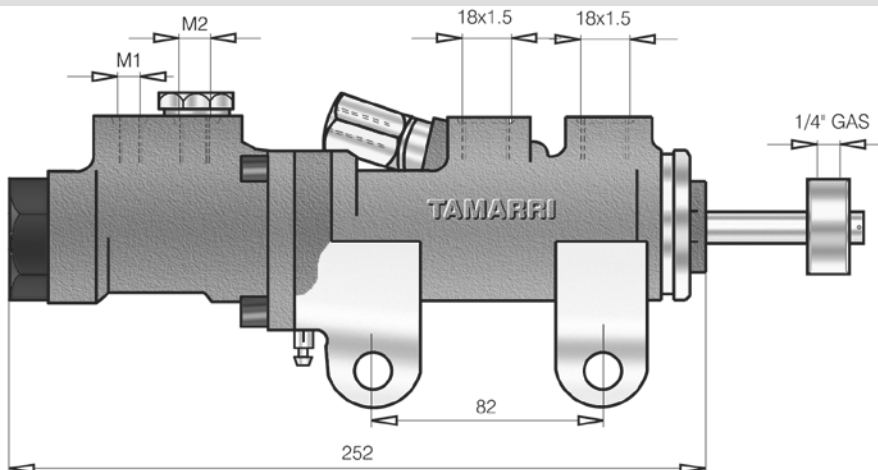

**M1**

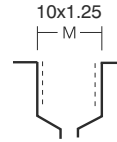

**M2**

Valvola 12x1.5

**M3**

**M4**

**Codici - Codes SAFIM**

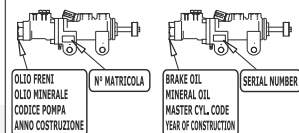

**MS130**

Cilindrata totale 19 cm<sup>3</sup> - Total displacement 19 cm<sup>3</sup>

OM

**POMPE MINISERVO - POWER CYLINDERS SAFIM**

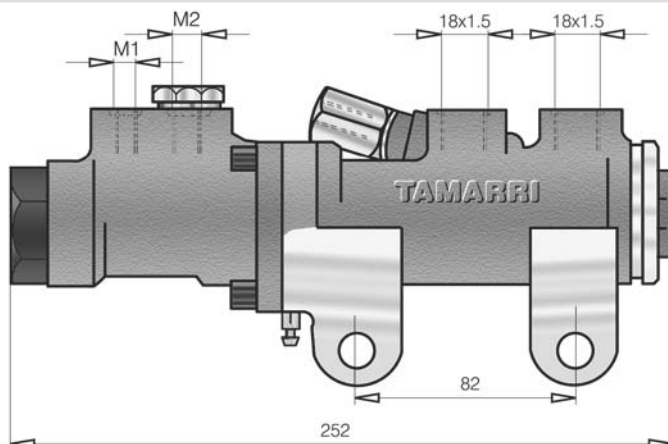

**M1**



**M2**

Valvola 12x1.5

**M3**

**M4**

**Codici - Codes SAFIM**

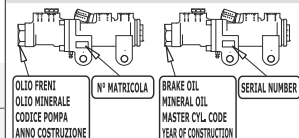

**MS208M**

Solo olio minerale - Mineral oil only

Manitou

**MS109**

Cilindrata totale 19 cm<sup>3</sup> - Total displacement 19 cm<sup>3</sup>

PGS - Robustus - Carer - Peralisi



I nostri ricambi non sono originali ma con essi perfettamente intercambiabili  
Our spare parts are not original but with them perfectly interchangeable



**POMPE FRENO MINISERVO  
POWER BRAKE CYLINDERS**

ADATTABILI SAFIM  
USED FOR SAFIM

A  
02

**POMPE MINISERVO - POWER CYLINDERS SAFIM**

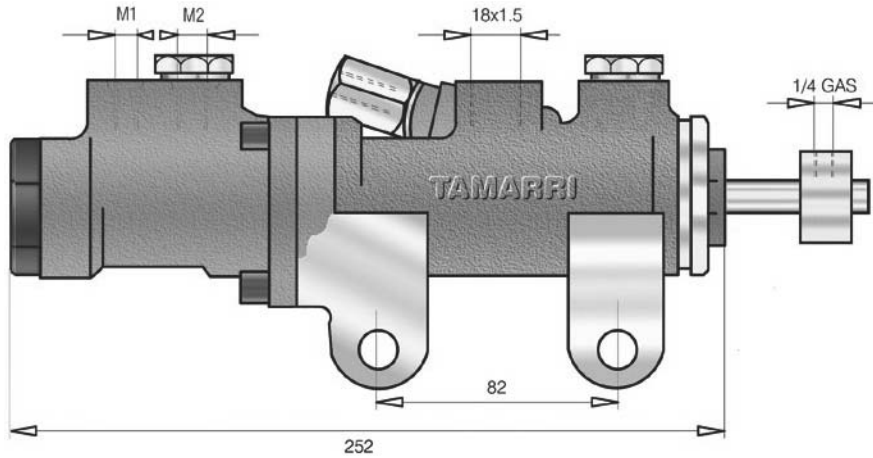

<b>M1</b>	<b>M2</b>
10x1.25 M	Valvola 12x1.5
<b>M3</b>	<b>M4</b>
<b>Codici - Codes SAFIM</b>	
OLIO FRENO OLIO MINERALE CODICE POMPA ANNO COSTRUZIONE	N° MATRICOLA BRAKE OIL MINERAL OIL MASTER CYL. CODE YEAR OF CONSTRUCTION

**MS163** Cilindrata totale 19 cm<sup>3</sup> - Total displacement 19 cm<sup>3</sup> Carer

**POMPE MINISERVO - POWER CYLINDERS SAFIM**

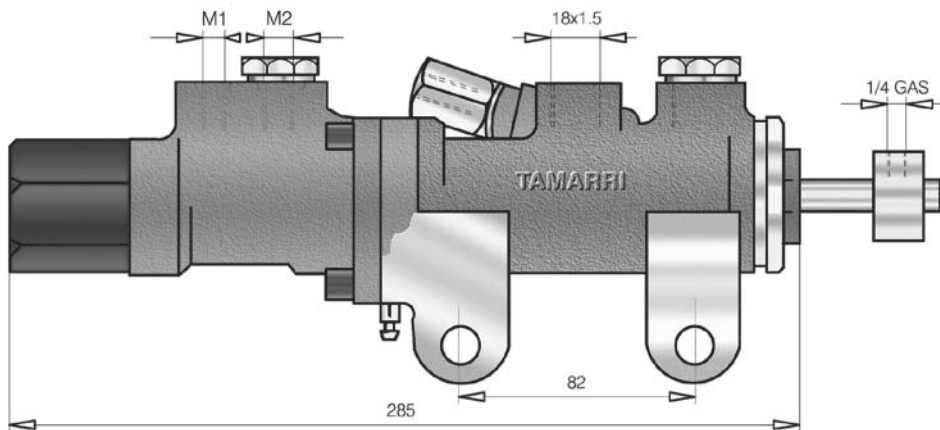

<b>M1</b>	<b>M2</b>
10x1.25 M	Valvola 12x1.5
<b>M3</b>	<b>M4</b>
<b>Codici - Codes SAFIM</b>	
OLIO FRENO OLIO MINERALE CODICE POMPA ANNO COSTRUZIONE	N° MATRICOLA BRAKE OIL MINERAL OIL MASTER CYL. CODE YEAR OF CONSTRUCTION

**MS134** Cilindrata totale 19 cm<sup>3</sup> - Total displacement 19 cm<sup>3</sup> Cesab

**POMPE MINISERVO - POWER CYLINDERS SAFIM**

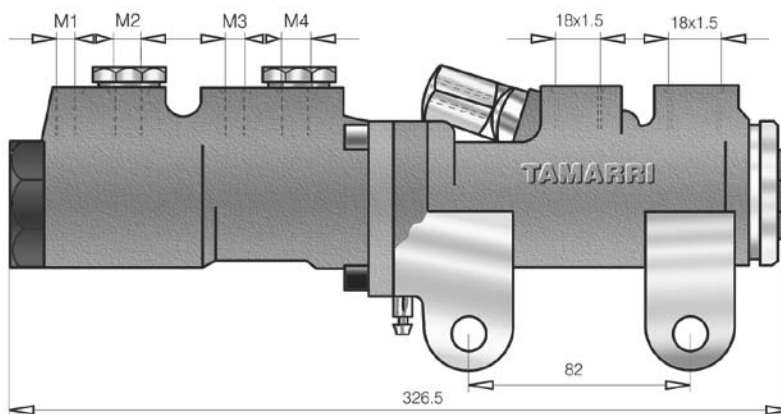

<b>M1</b>	<b>M2</b>
12x1.5 M	Valvola 12x1.5
<b>M3</b>	<b>M4</b>
12x1.5 M	Valvola 12x1.5
<b>Codici - Codes SAFIM</b>	
OLIO FRENO OLIO MINERALE CODICE POMPA ANNO COSTRUZIONE	N° MATRICOLA BRAKE OIL MINERAL OIL MASTER CYL. CODE YEAR OF CONSTRUCTION

**MS128M** Solo olio minerale - Mineral oil only Fantuzzi

**MS128** Cilindrata totale 54 cm<sup>3</sup> - Total displacement 54 cm<sup>3</sup> Fiat Allis - Benfra - FAI



I nostri ricambi non sono originali ma con essi perfettamente intercambiabili  
Our spare parts are not original but with them perfectly interchangeable



**POMPE FRENO MINISERVO  
POWER BRAKE CYLINDERS**

ADATTABILI SAFIM  
USED FOR SAFIM

A  
02

POMPE MINISERVO - POWER CYLINDERS SAFIM		M1	M2
			Valvola 12x1.5
			Valvola 12x1.5
		<b>Codici - Codes SAFIM</b>	
<b>MS149</b>	Cilindrata totale 54 cm <sup>3</sup> - Total displacement 54 cm <sup>3</sup>		
Benfra - Fai - Benati			

POMPE MINISERVO - POWER CYLINDERS SAFIM		M1	M2
		<b>Codici - Codes SAFIM</b>	
<b>MS168</b>	Tandem - cilindrata: min 24 cm <sup>3</sup> - max 49 cm <sup>3</sup> Tandem - displacement: min 24 cm <sup>3</sup> - max 49 cm <sup>3</sup>		
Benfra			

POMPE MINISERVO - POWER CYLINDERS SAFIM		M1	M2
			Valvola 12x1.5
			Valvola 12x1.5
		<b>Codici - Codes SAFIM</b>	
<b>MS187</b>	Tandem - 1° Circuito 27 cm <sup>3</sup> - 2° Circuito 27 cm <sup>3</sup> Tandem - 1° Circuit 27 cm <sup>3</sup> - 2° Circuit 27 cm <sup>3</sup>		



I nostri ricambi non sono originali ma con essi perfettamente intercambiabili  
Our spare parts are not original but with them perfectly interchangeable



**POMPE FRENO MINISERVO  
POWER BRAKE CYLINDERS**

ADATTABILI SAFIM  
USED FOR SAFIM

A  
02

**POMPE MINISERVO - POWER CYLINDERS SAFIM**

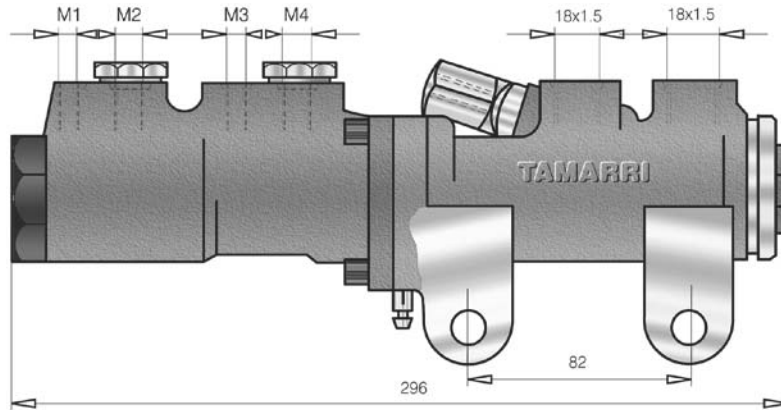

<b>M1</b>	<b>M2</b>
	Valvola 12x1.5
<b>M3</b>	<b>M4</b>
	Valvola 12x1.5
<b>Codici - Codes SAFIM</b>	
OLIO FRENO OLIO MINERALE CODICE POMPA ANNO COSTRUZIONE	N° MATRICOLA BRAKE OIL MINERAL OIL MASTER CYL. CODE YEAR OF CONSTRUCTION

<b>MS107.1M</b>	Cilindrata Totale 18,5 cm <sup>3</sup> olio minerale Total Displacement 18 cm <sup>3</sup> Mineral oil only	PGS-Benfra
<b>MS107.1</b>	Cilindrata Totale 18,5 cm <sup>3</sup> - Total Displacement 18 cm <sup>3</sup>	

**POMPE MINISERVO - POWER CYLINDERS SAFIM**

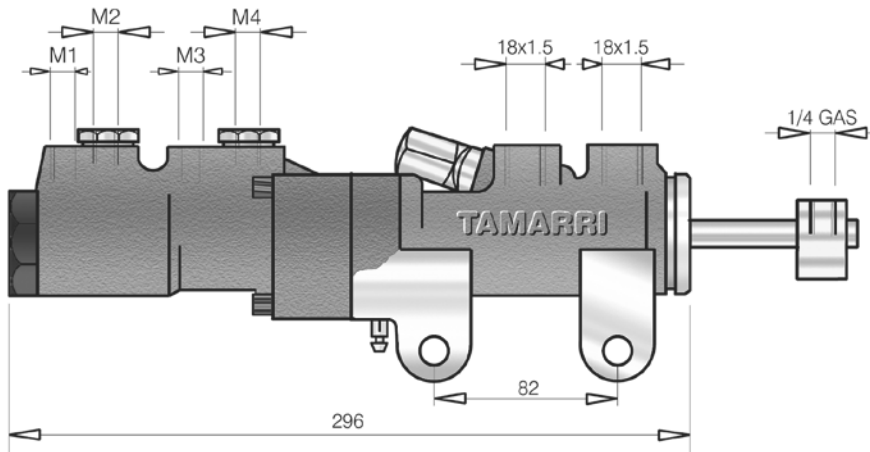

<b>M1</b>	<b>M2</b>
	Valvola 12x1.5
<b>M3</b>	<b>M4</b>
	Valvola 12x1.5
<b>Codici - Codes SAFIM</b>	
OLIO FRENO OLIO MINERALE CODICE POMPA ANNO COSTRUZIONE	N° MATRICOLA BRAKE OIL MINERAL OIL MASTER CYL. CODE YEAR OF CONSTRUCTION

<b>MS173</b>	Cilindrata 18.5 cm <sup>3</sup> - Displacement 18.5 cm <sup>3</sup>	F.lli Dieci
--------------	---	-------------

**POMPE MINISERVO - POWER CYLINDERS SAFIM**

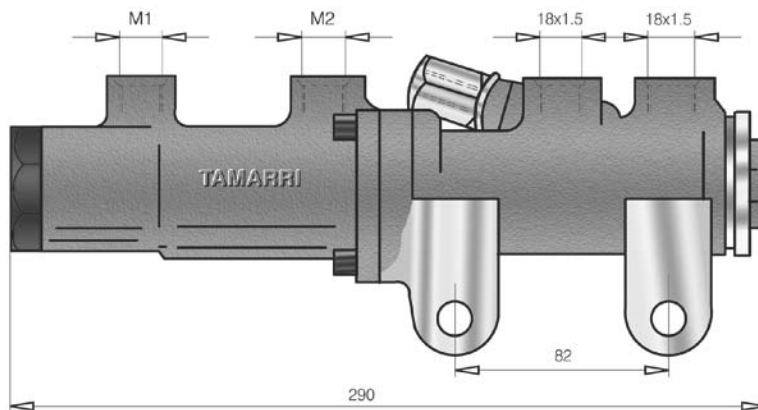

<b>M1</b>	<b>M2</b>
<b>M3</b>	<b>M4</b>
<b>Codici - Codes SAFIM</b>	
OLIO FRENO OLIO MINERALE CODICE POMPA ANNO COSTRUZIONE	N° MATRICOLA BRAKE OIL MINERAL OIL MASTER CYL. CODE YEAR OF CONSTRUCTION

<b>MS167</b>	Cilindrata: Min 27.5 cm <sup>3</sup> - Max 49 cm <sup>3</sup> Displacement: Min 27.5 Cm <sup>3</sup> - Max 49 Cm <sup>3</sup>	Benfra
<b>MS167M</b>	Cilindrata: Min 27.5 cm <sup>3</sup> - Max 49 cm <sup>3</sup> olio minerale Displacement: Min 27.5 Cm <sup>3</sup> - Max 49 Cm <sup>3</sup> Mineral oil only	Benfra



I nostri ricambi non sono originali ma con essi perfettamente intercambiabili  
Our spare parts are not original but with them perfectly interchangeable



**POMPE FRENO MINISERVO  
POWER BRAKE CYLINDERS**

ADATTABILI SAFIM  
USED FOR SAFIM

A  
02

POMPE MINISERVO - POWER CYLINDERS SAFIM		M1	M2
		M3	M4
		<b>Codici - Codes SAFIM</b>	
<b>MS108/A</b>	Cilindrata: Min 27.5 Cm <sup>3</sup> - Max 49 Cm <sup>3</sup> Displacement: Min 27.5 Cm <sup>3</sup> - Max 49 Cm <sup>3</sup>	F.lli Dieci - Benfra	

POMPE MINISERVO - POWER CYLINDERS SAFIM		M1	M2
		M3	M4
		<b>Codici - Codes SAFIM</b>	
<b>MS159</b>	Tandem - Cilindrata: Min 27.5 Cm <sup>3</sup> - Max 49 Cm <sup>3</sup> Tandem - Displacement: Min 27.5 Cm <sup>3</sup> - Max 49 Cm <sup>3</sup>	Benfra	

POMPE MINISERVO - POWER CYLINDERS SAFIM		M1	M2
		M3	M4
		<b>Codici - Codes SAFIM</b>	
<b>MS108M</b>	Cilindrata: Min 19 cm <sup>3</sup> - Max 44 cm <sup>3</sup> - olio minerale Displacement: Min 19 cm <sup>3</sup> - Max 44 cm <sup>3</sup> - Mineral oil only	Manitou	
<b>MS108</b>	Cilindrata: Min 19 Cm <sup>3</sup> - Max 44 Cm <sup>3</sup> Displacement: Min 19 Cm <sup>3</sup> - Max 44 Cm <sup>3</sup>	Cesab - F.lli Dieci	



I nostri ricambi non sono originali ma con essi perfettamente intercambiabili  
Our spare parts are not original but with them perfectly interchangeable



**POMPE FRENO MINISERVO  
POWER BRAKE CYLINDERS**

ADATTABILI SAFIM  
USED FOR SAFIM

A  
02

**POMPE MINISERVO - POWER CYLINDERS SAFIM**

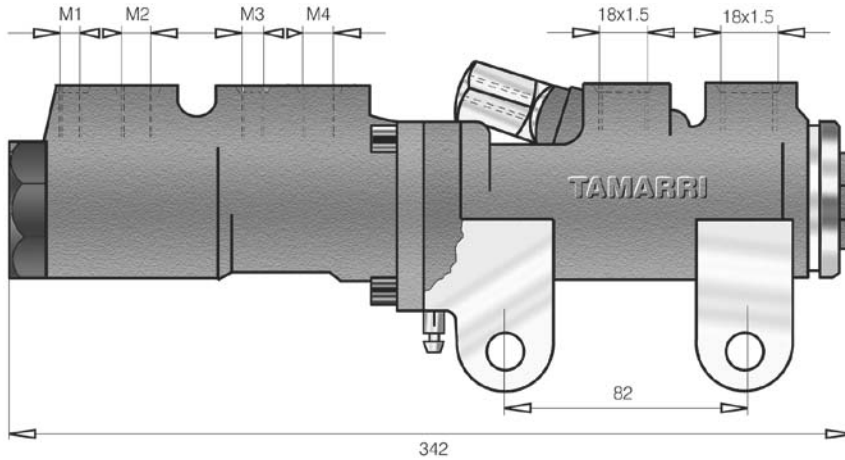

<b>M1</b> 12x1.5 M	<b>M2</b> 18x1.5 M
<b>M3</b> 12x1.5 M	<b>M4</b> 18x1.5 M
<b>Codici - Codes SAFIM</b>	
OLIO FRENI OLIO MINERALE CODICE POMPA ANNO COSTRUZIONE	N° MATRICOLA BRAKE OIL MINERAL OIL MASTER CYL. CODE YEAR OF CONSTRUCTION

**MS107** Cilindrata: Min 18.5 Cm<sup>3</sup> - Max 43.5 Cm<sup>3</sup>  
Displacement: Min 18.5 Cm<sup>3</sup> - Max 43.5 Cm<sup>3</sup> Benfra - Benati

**POMPE MINISERVO - POWER CYLINDERS SAFIM**

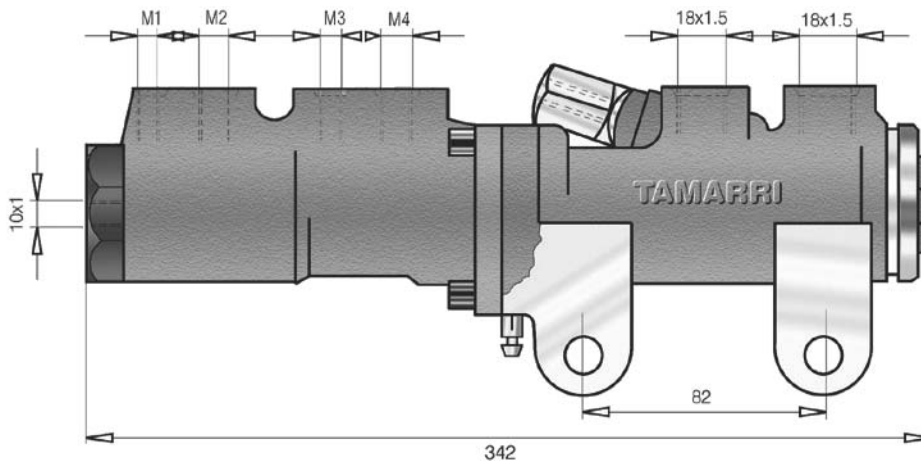

<b>M1</b> 12x1.5 M	<b>M2</b> 18x1.5 M
<b>M3</b> 12x1.5 M	<b>M4</b> 18x1.5 M
<b>Codici - Codes SAFIM</b>	
OLIO FRENI OLIO MINERALE CODICE POMPA ANNO COSTRUZIONE	N° MATRICOLA BRAKE OIL MINERAL OIL MASTER CYL. CODE YEAR OF CONSTRUCTION

**MS157** Cilindrata: Min 18.5 Cm<sup>3</sup> - Max 43.5 Cm<sup>3</sup>  
Displacement: Min 18.5 Cm<sup>3</sup> - Max 43.5 Cm<sup>3</sup> Manitou

**POMPE MINISERVO - POWER CYLINDERS SAFIM**

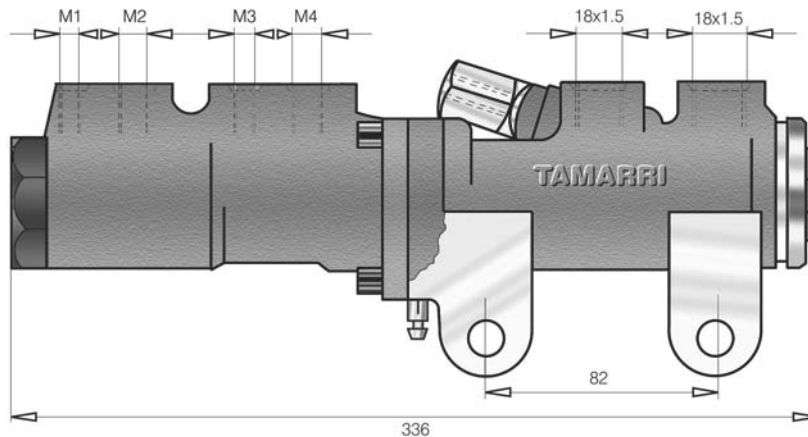

<b>M1</b> 12x1.5 M	<b>M2</b> 18x1.5 M
<b>M3</b> 12x1.5 M	<b>M4</b> 18x1.5 M
<b>Codici - Codes SAFIM</b>	
OLIO FRENI OLIO MINERALE CODICE POMPA ANNO COSTRUZIONE	N° MATRICOLA BRAKE OIL MINERAL OIL MASTER CYL. CODE YEAR OF CONSTRUCTION

**MS110** Cilindrata: Min 26.5 cm<sup>3</sup> - Max 48 cm<sup>3</sup>  
Displacement: Min 26.5 cm<sup>3</sup> - Max 48 cm<sup>3</sup> Bationi & Pagani - Fantuzzi -  
Fiori - Robustus  
**MS110M** Cilindrata: Min 26.5 cm<sup>3</sup> - Max 48 cm<sup>3</sup> - olio minerale  
Displacement: Min 26,5 cm<sup>3</sup> - Max 48 cm<sup>3</sup> - Mineral oil only



I nostri ricambi non sono originali ma con essi perfettamente intercambiabili  
Our spare parts are not original but with them perfectly interchangeable



**POMPE FRENO MINISERVO  
POWER BRAKE CYLINDERS**

ADATTABILI SAFIM  
USED FOR SAFIM

A  
02

**POMPE MINISERVO - POWER CYLINDERS SAFIM**

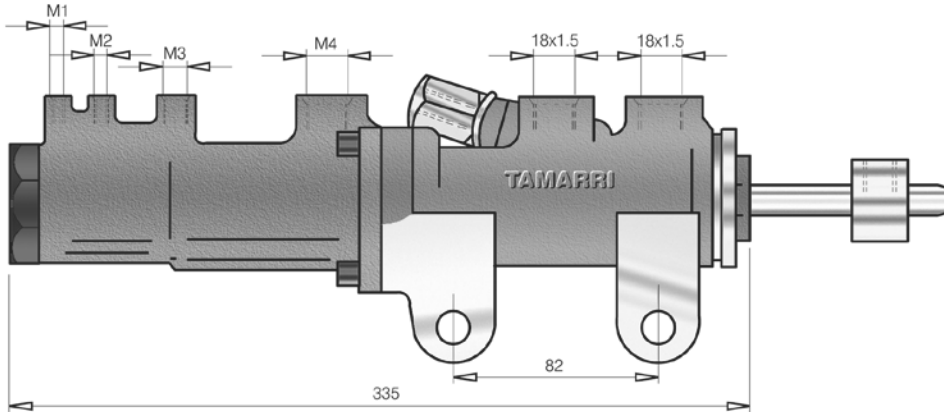

<b>M1</b> 12x1.5 M	<b>M2</b> 18x1.5 M
<b>M3</b> 12x1.5 M	<b>M4</b> 18x1.5 M

**Codici - Codes SAFIM**

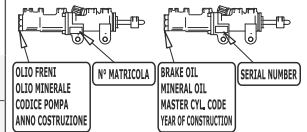

**MS203** Cilindrata: Min 20.5 Cm<sup>3</sup> - Max 48.5 Cm<sup>3</sup>  
Displacement: Min 20.5 Cm<sup>3</sup> - Max 48.5 Cm<sup>3</sup>

**MS148** Cilindrata: Min 26.5 Cm<sup>3</sup> - Max 48 Cm<sup>3</sup>  
Displacement: Min 26.5 Cm<sup>3</sup> - Max 48 Cm<sup>3</sup>

Battoni & Pagani

**POMPE MINISERVO - POWER CYLINDERS SAFIM**

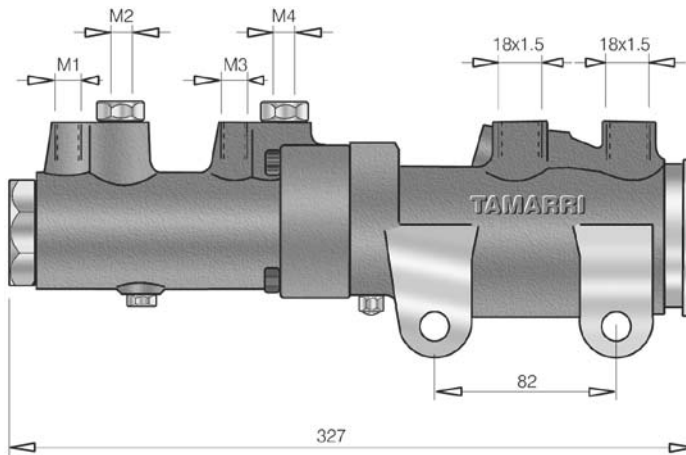

<b>M1</b> 14x1.5 M	<b>M2</b> Valvola 12x1.5
<b>M3</b> 14x1.5 M	<b>M4</b> Valvola 12x1.5

**Codici - Codes SAFIM**

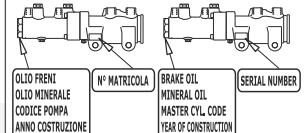

**MS171** Servofreno idraulico - Tandem - 1° Circuito 30 cm<sup>3</sup> - 2° Circuito 35 cm<sup>3</sup> Fiat Allis  
Hydraulic brake booster - Tandem - 1° Circuit 30 cm<sup>3</sup> - 2° Circuit 35 cm<sup>3</sup>

**POMPE MINISERVO - POWER CYLINDERS SAFIM**

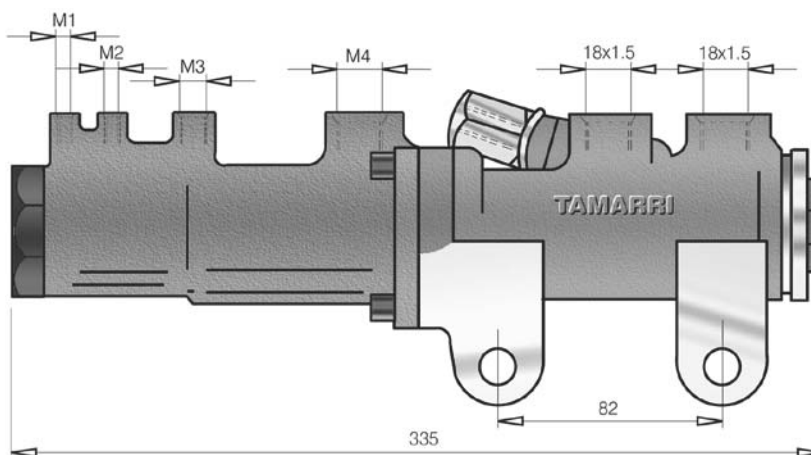

<b>M1</b> 12x1.5 M	<b>M2</b> 18x1.5 M
<b>M3</b> 12x1.5 M	<b>M4</b> 18x1.5 M

**Codici - Codes SAFIM**

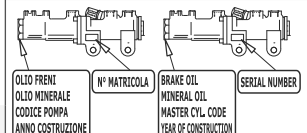

**MS178** Cilindrata: Min 3.9 Cm<sup>3</sup> - Max 31.9 Cm<sup>3</sup>  
Displacement: Min 3.9 Cm<sup>3</sup> - Max 31.9 Cm<sup>3</sup>

Benati



I nostri ricambi non sono originali ma con essi perfettamente intercambiabili  
Our spare parts are not original but with them perfectly interchangeable





**POMPE FRENO MINISERVO  
POWER BRAKE CYLINDERS**

ADATTABILI SAFIM  
USED FOR SAFIM

A  
02

**POMPE MINISERVO - POWER CYLINDERS SAFIM**

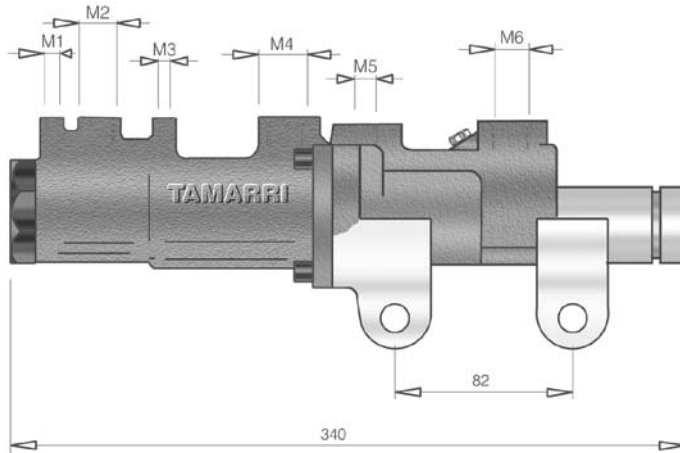

**M1-M3**

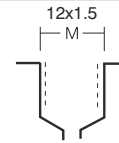

**M2-M4-M6**

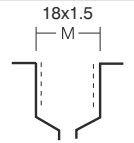

**M5**

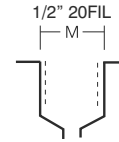

**Codici - Codes SAFIM**

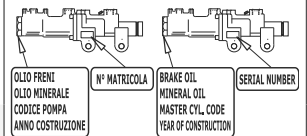

**MS177M**

Cilindrata: Min 18.5 cm<sup>3</sup> - Max 43.5 cm<sup>3</sup> - Olio Minerale  
Displacement: Min 18.5 cm<sup>3</sup> - Max 43.5 cm<sup>3</sup> - Mineral Oil

Manitou

**POMPE MINISERVO - POWER CYLINDERS SAFIM**

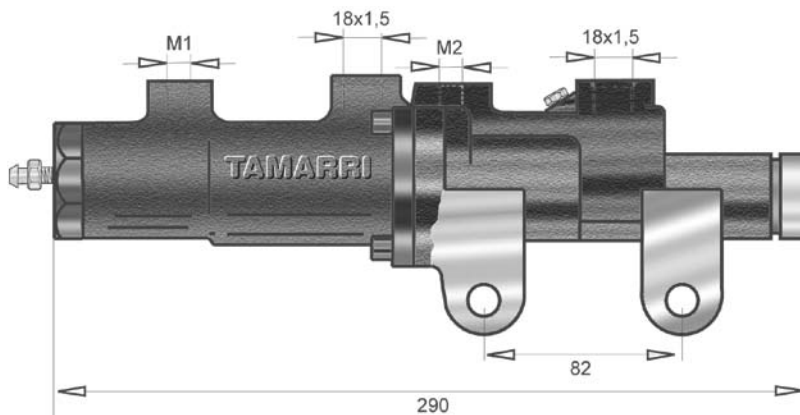

**M1**

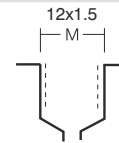

**M2**

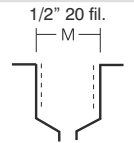

**M3**

**M4**

**Codici - Codes SAFIM**

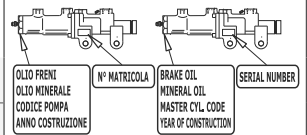

**MS188M**

Cilindrata: Min 18 cm<sup>3</sup> - Max 43 cm<sup>3</sup> - Olio minerale  
Displacement: Min 18 cm<sup>3</sup> - Max 43 cm<sup>3</sup> - Mineral oil only

Manitou

**MS191**

Cilindrata: Min 26.5 cm<sup>3</sup> - Max 48 cm<sup>3</sup> - Olio minerale  
Displacement: Min 26.5 cm<sup>3</sup> - Max 48 cm<sup>3</sup> - Mineral oil only

Komatsu

**POMPE MINISERVO - POWER CYLINDERS SAFIM Ø 22.2 - 15.6**

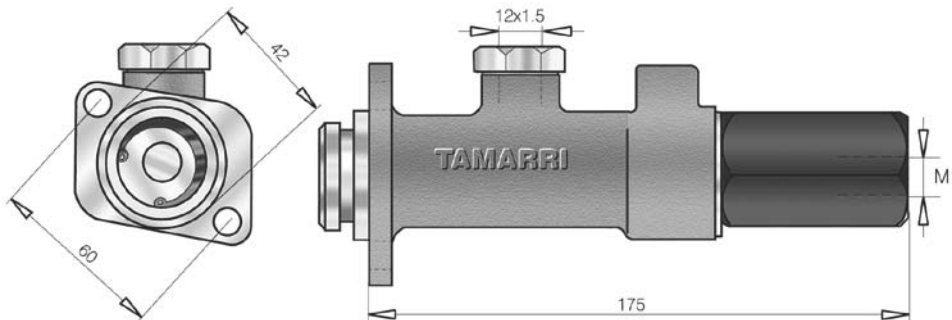

**M1**

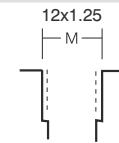

**M2**

**M3**

**M4**

**Codici - Codes SAFIM**

**MS122**

Olio freni DOT3-4 - Brake oil DOT3-4

Cesab



I nostri ricambi non sono originali ma con essi perfettamente intercambiabili  
Our spare parts are not original but with them perfectly interchangeable



**POMPE FRENO MINISERVO  
POWER BRAKE CYLINDERS**

ADATTABILI SAFIM  
USED FOR SAFIM

A  
02

**POMPE MINISERVO - POWER CYLINDERS SAFIM Ø 27/20"**

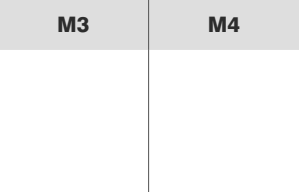
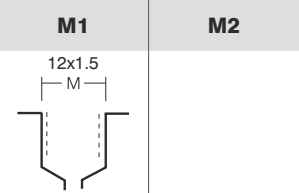
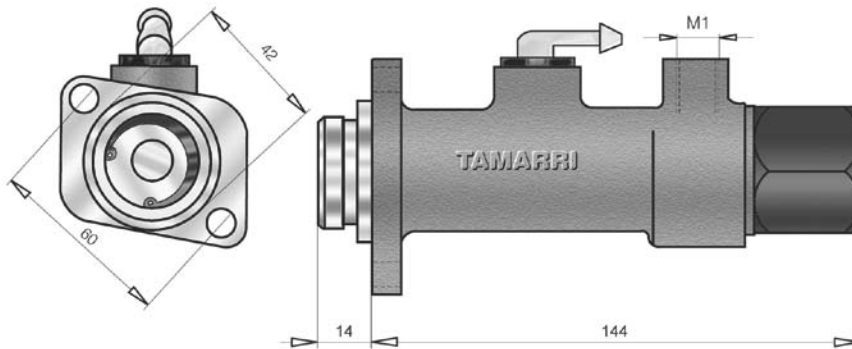

**Codici - Codes SAFIM**

- |               |                                       |                 |
|---------------|---------------------------------------|-----------------|
| <b>MS126</b>  | Olío freni DOT3-4 - Brake oil DOT3-4  | Sibicar - Cesab |
| <b>MS224M</b> | Solo olio minerale - Mineral oil only |                 |

**POMPE MINISERVO - POWER CYLINDERS SAFIM Ø 27/20"**

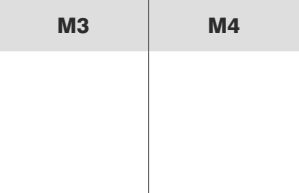
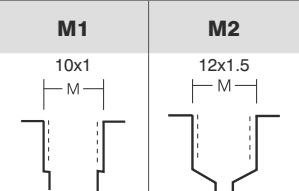
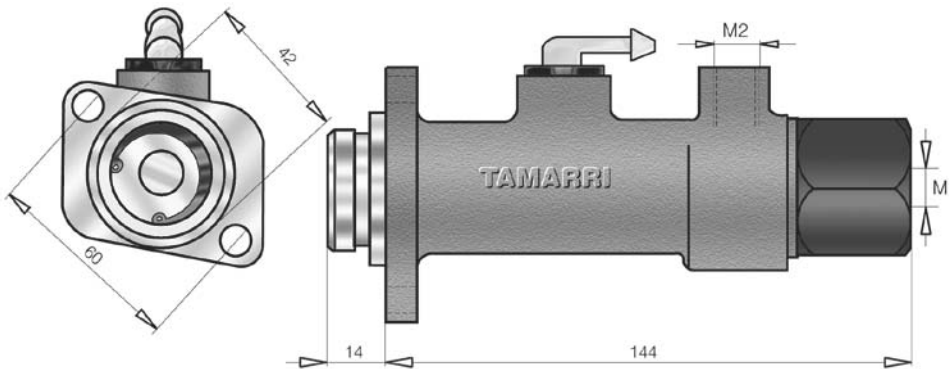

**Codici - Codes SAFIM**

- |               |                                       |                     |
|---------------|---------------------------------------|---------------------|
| <b>MS138M</b> | Solo olio minerale - Mineral oil only | Merlo - Fai - Cesab |
| <b>MS138</b>  | Olío freni DOT3-4 - Brake oil DOT3-4  |                     |

**POMPE MINISERVO - POWER CYLINDERS SAFIM Ø 27/20" Montaggio Verticale**

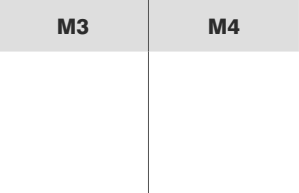
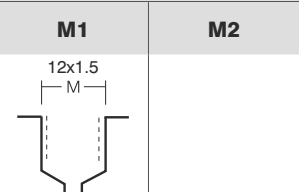
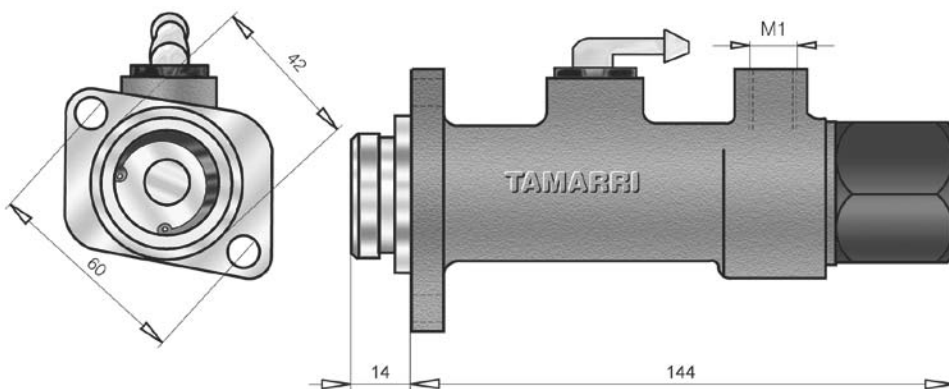

**Codici - Codes SAFIM**

- |               |                                       |  |
|---------------|---------------------------------------|--|
| <b>MS216M</b> | Solo olio minerale - Mineral oil only |  |
|---------------|---------------------------------------|--|



I nostri ricambi non sono originali ma con essi perfettamente intercambiabili  
Our spare parts are not original but with them perfectly interchangeable



**POMPE FRENO MINISERVO  
POWER BRAKE CYLINDERS**

ADATTABILI SAFIM  
USED FOR SAFIM

A  
02

POMPE MINISERVO - POWER CYLINDERS SAFIM		M1	M2
		M3	M4
		<b>Codici - Codes SAFIM</b>	
<b>MS184M</b>	Montata con PF109 - Servofreno idraulico - Olio Minerale Assembled with PF109 - Hydraulic brake booster - Mineral Oil		Venieri

POMPE MINISERVO - POWER CYLINDERS SAFIM Ø 38/25" 31,75 mm		M1	M2
		<b>Codici - Codes SAFIM</b>	
<b>MS189</b>	Olio freni DOT3-4 - Brake oil DOT3-4		LC Corà
<b>MS189M</b>	Solo olio minerale - Mineral oil only		Benati - Fiori

POMPE MINISERVO - POWER CYLINDERS SAFIM Ø 38/25"		M1	M2
		M3	M4
		<b>Codici - Codes SAFIM</b>	
<b>MS200</b>	Olio freni DOT3-4 - Brake oil DOT3-4		LC Corà



I nostri ricambi non sono originali ma con essi perfettamente intercambiabili  
Our spare parts are not original but with them perfectly interchangeable



**POMPE FRENO MINISERVO  
POWER BRAKE CYLINDERS**

ADATTABILI SAFIM  
USED FOR SAFIM

A  
02

**POMPE MINISERVO - POWER CYLINDERS SAFIM**

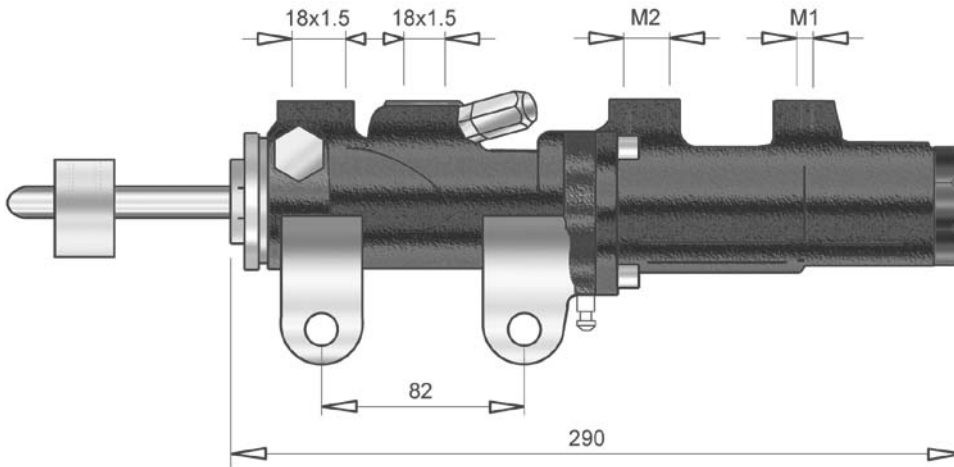

<b>M1</b> 12x1.5 M	<b>M2</b> 18x1.5 M
<b>M3</b>	<b>M4</b>

Codici - Codes SAFIM

**MS136** Cilindrata: Min 19 Cm<sup>3</sup> - Max 44 Cm<sup>3</sup>  
Displacement: Min 19 Cm<sup>3</sup> - Max 44 Cm<sup>3</sup> Bationi e Pagani

**POMPE MINISERVO - POWER CYLINDERS SAFIM**

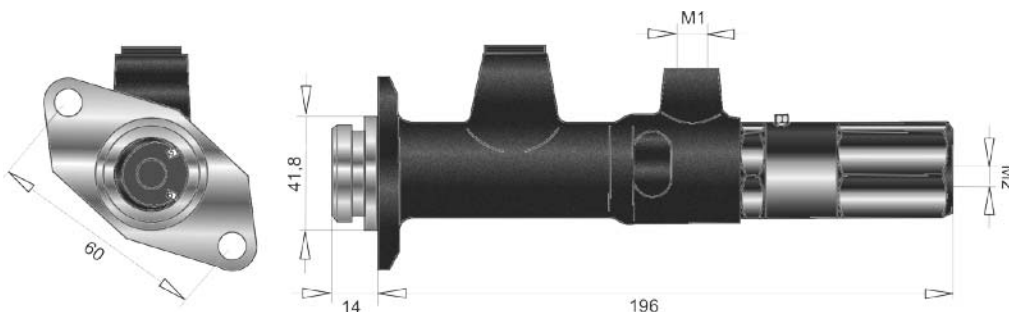

<b>M1</b> 12x1.5 M	<b>M2</b> 10x1 M
<b>M3</b>	<b>M4</b>

Codici - Codes SAFIM

**MS201M** Solo olio minerale - Mineral oil only FAI-Komatsu

**POMPE MINISERVO - POWER CYLINDERS SAFIM Pompa Differenziale**

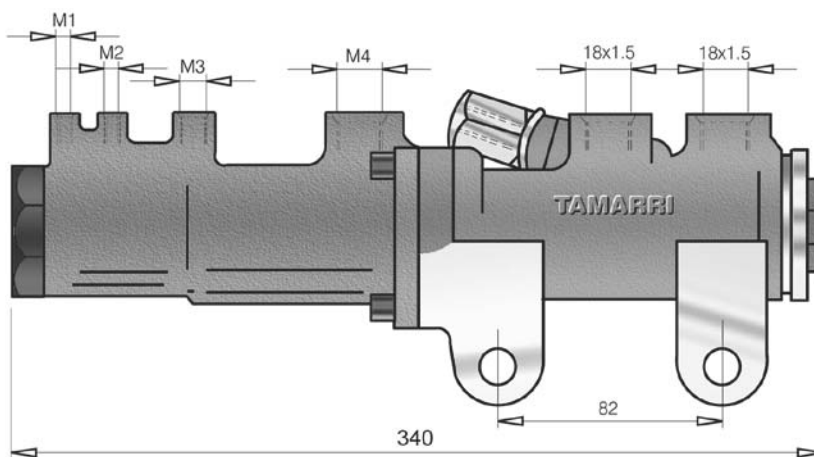

<b>M1</b> 12x1.5 M	<b>M2</b> 18x1.5 M
<b>M3</b> 12x1.5 M	<b>M4</b> 18x1.5 M

Codici - Codes SAFIM

**MS211** 1° Circuito min. 5cm<sup>3</sup> max.30cm<sup>3</sup>  
2° Circuito fissa 13,5cm<sup>3</sup> Spazzatrice



I nostri ricambi non sono originali ma con essi perfettamente intercambiabili  
Our spare parts are not original but with them perfectly interchangeable



**POMPE FRENO MINISERVO  
POWER BRAKE CYLINDERS**

ADATTABILI SAFIM  
USED FOR SAFIM

A  
02

PEDALIERA FRENO IDRAULICA - HYDRAULIC BRAKE PEDAL		M1	M2
		M3	M4
		Codici - Codes SAFIM	
<b>MS155</b>	Pedaliera freni - Brake pedal	OM	

PEDALIERA FRENO IDRAULICA - HYDRAULIC BRAKE PEDAL		M1	M2
		M3	M4
		Codici - Codes SAFIM	
<b>MS215</b>	Pedaliera freni - Brake pedal	Fantuzzi	

POMPE MINISERVO - POWER CYLINDERS SAFIM Ø 1" 1/4 - 31.75		M1	M2
		M3	M4
		Codici - Codes SAFIM	
<b>MS202</b>	Olio freni DOT3-4 - Brake oil DOT3-4		



I nostri ricambi non sono originali ma con essi perfettamente intercambiabili  
Our spare parts are not original but with them perfectly interchangeable



**POMPE FRENO MINISERVO  
POWER BRAKE CYLINDERS**

ADATTABILI SAFIM  
USED FOR SAFIM

A  
02

**POMPE MINISERVO - POWER CYLINDERS SAFIM Ø 1" 1/4 - 31.75**

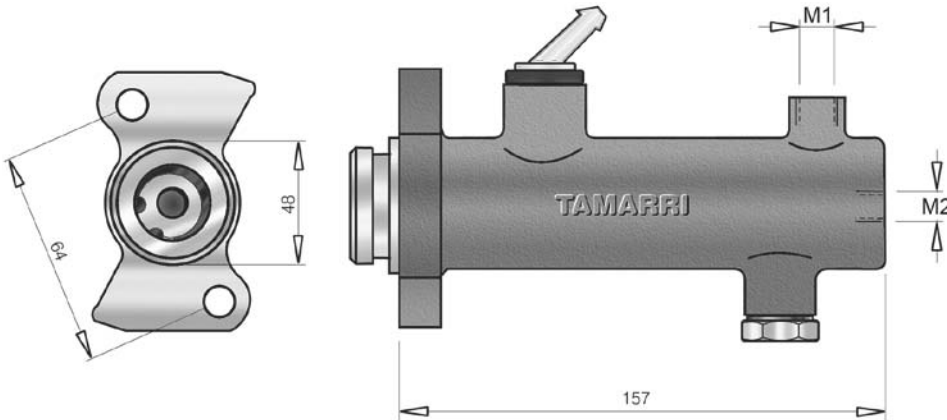

<b>M1</b>	<b>M2</b>
14x1.5 M	10x1 M
<b>M3</b>	<b>M4</b>

**Codici - Codes SAFIM**

**MS166M** Solo olio minerale - Mineral oil only

Raniero

**POMPE MINISERVO - POWER CYLINDERS SAFIM**

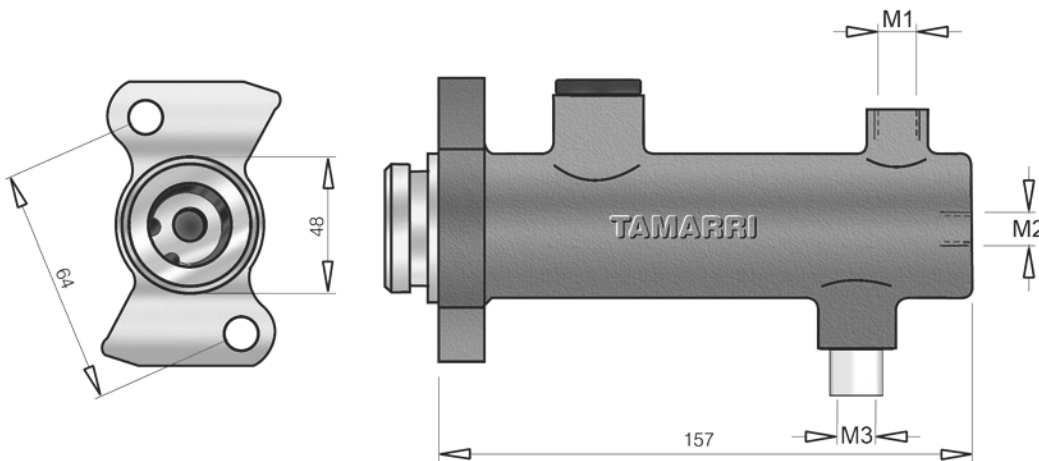

<b>M1</b>	<b>M2</b>
14x1.5 M	10x1 M
<b>M3</b>	<b>M4</b>
10x1 M	

**Codici - Codes SAFIM**

**MS225M** Solo olio minerale - Mineral oil only

Komatsu

**POMPE MINISERVO - POWER CYLINDERS SAFIM**

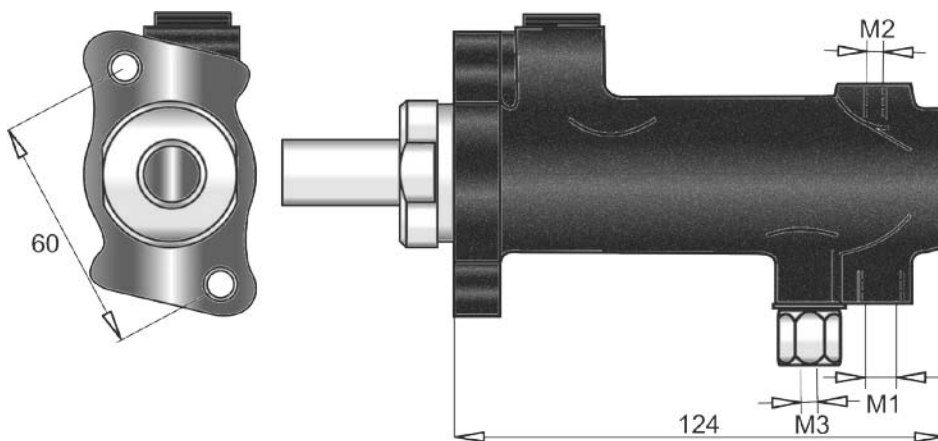

<b>M1</b>	<b>M2</b>
14x1.5 M	10x1 M
<b>M3</b>	<b>M4</b>
10x1 M	

**Codici - Codes SAFIM**

**MS193M** Solo olio minerale - Mineral oil only

Komatsu



I nostri ricambi non sono originali ma con essi perfettamente intercambiabili  
Our spare parts are not original but with them perfectly interchangeable



**POMPE FRENO MINISERVO  
POWER BRAKE CYLINDERS**

ADATTABILI SAFIM  
USED FOR SAFIM

A  
02

**POMPE MINISERVO - POWER CYLINDERS SAFIM Ø 35-20mm**

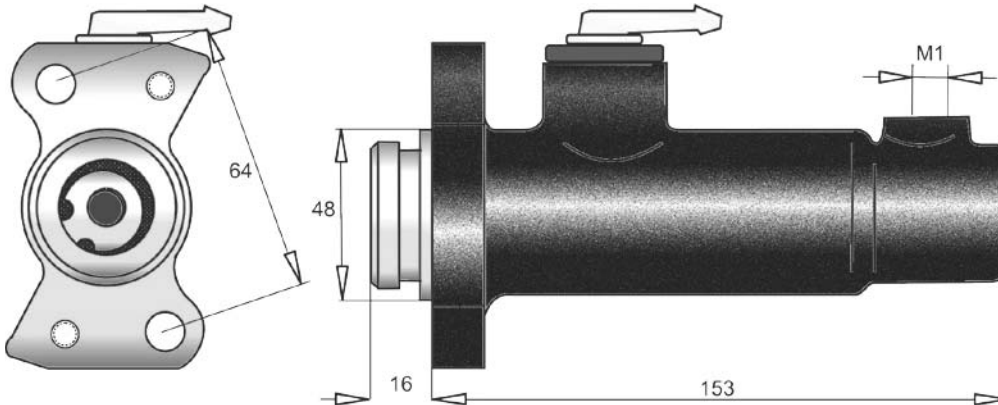

**M1**

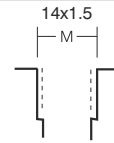

**M2**

**M3**

**M4**

**Codici - Codes SAFIM**

**MS233** Olio freni DOT3-4 - Brake oil DOT3-4

Detas

**POMPE MINISERVO - POWER CYLINDERS SAFIM**

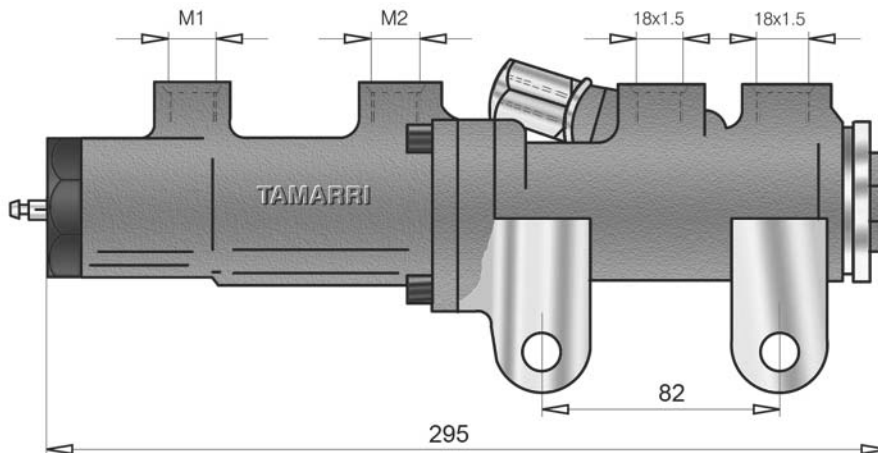

**M1**

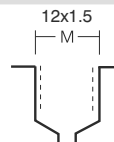

**M2**

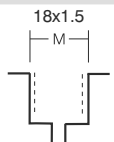

**M3**

**M4**

**Codici - Codes SAFIM**

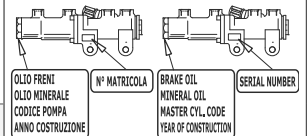

**MS227M** 40 bar - olio minerale  
40 bar - Mineral oil only

Manitou

**POMPE MINISERVO - POWER CYLINDERS SAFIM**

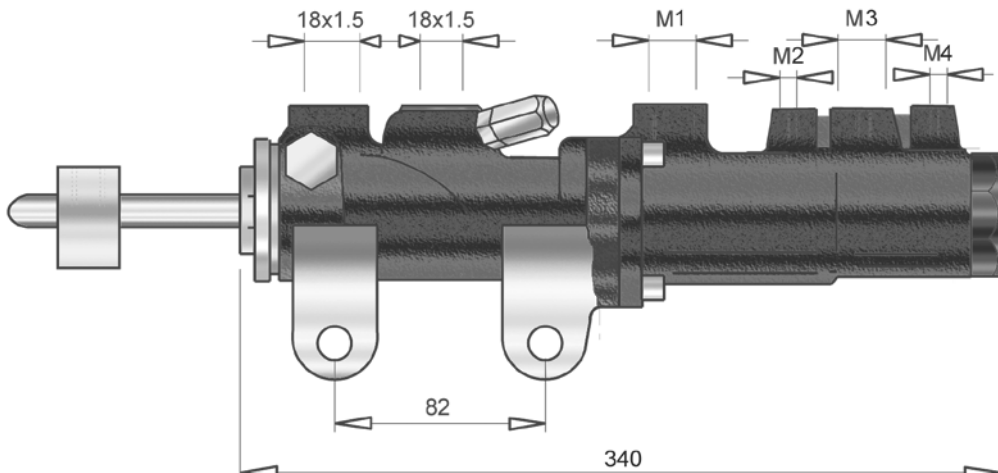

**M1**

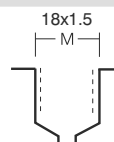

**M2**

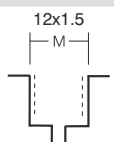

**M3**

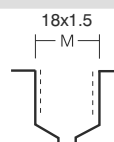

**M4**

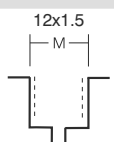

**Codici - Codes SAFIM**

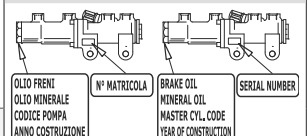

**MS228** Cilindrata: Min 18,5 Cm<sup>3</sup> - Max 43,5 Cm<sup>3</sup>  
Displacement: Min 18,5 Cm<sup>3</sup> - Max 43,5 Cm<sup>3</sup>



I nostri ricambi non sono originali ma con essi perfettamente intercambiabili  
Our spare parts are not original but with them perfectly interchangeable



**POMPE FRENO MINISERVO  
POWER BRAKE CYLINDERS**

ADATTABILI SAFIM  
USED FOR SAFIM

A  
02

**POMPE MINISERVO - POWER CYLINDERS SAFIM**

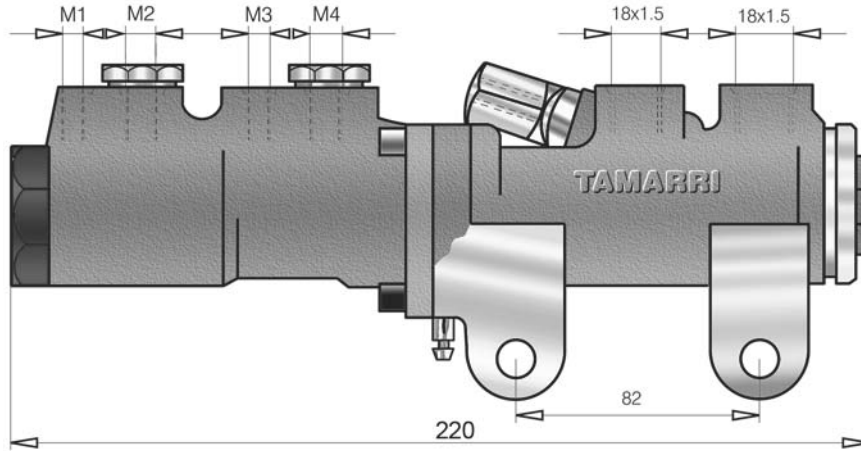

**M1**

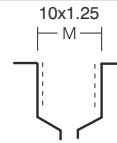

**M2**

Valvola 12x1,5

**M3**

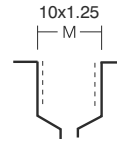

**M4**

Valvola 12x1,5

**Codici - Codes SAFIM**

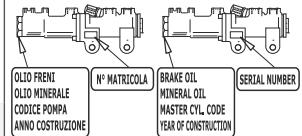

**MS226**

Cilindrata: Min 9 Cm<sup>3</sup> - Max 9,50 Cm<sup>3</sup>  
Displacement: Min 9 Cm<sup>3</sup> - Max 9,50 Cm<sup>3</sup>

Zefir

**POMPE MINISERVO - POWER CYLINDERS SAFIM**

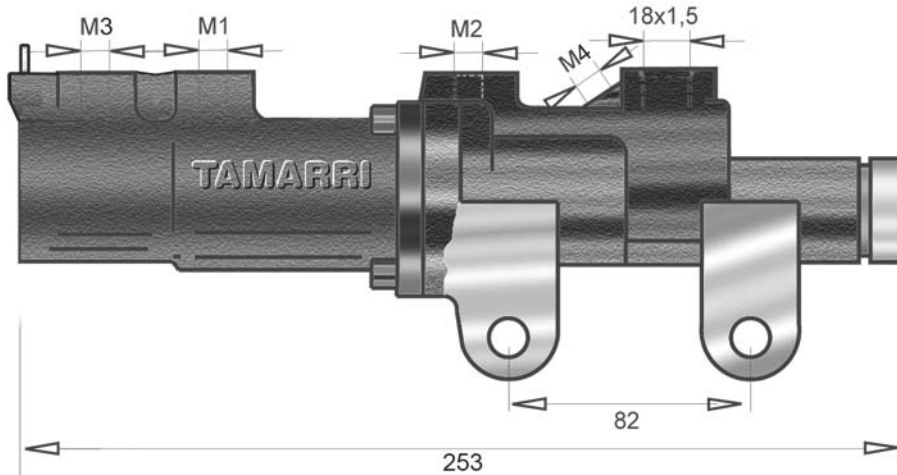

**M1**

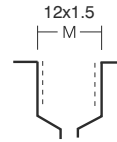

**M2**

1/2" 20fil

**M3**

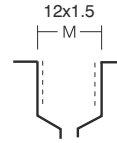

**M4**

10x1

**Codici - Codes SAFIM**

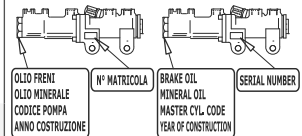

**MS230M**

Cilindrata: Min 18 cm<sup>3</sup> - Max 43 cm<sup>3</sup> - Olio minerale  
Displacement: Min 18 cm<sup>3</sup> - Max 43 cm<sup>3</sup> - Mineral oil only

Manitou







**POMPE FRENO MINISERVO  
POWER BRAKE CYLINDERS**

ADATTABILI SAFIM  
USED FOR SAFIM



**POMPE FRENO MINISERVO  
POWER BRAKE CYLINDERS**

ADATTABILI VARI MODELLI  
USED FOR DIFFERENT MODELS

A  
02

POMPE MINISERVO - POWER CYLINDERS Ø 27/20"		M1	M2
		M3	M4
		<b>Uscita Olio - Oil exit</b>	
<b>MS102M</b>	Solo olio minerale - Mineral oil only		
<b>MS102</b>	Olio freni DOT3-4 - Brake oil DOT3-4	Lugli - Cesab - Azzolini	

POMPE MINISERVO - POWER CYLINDERS Ø 27/20"		M1	M2
		M3	M4
		<b>Uscita Olio - Oil exit</b>	
<b>MS101M</b>	Solo olio minerale - Mineral oil only		
<b>MS101</b>	Olio freni DOT3-4 - Brake oil DOT3-4	Cesab - Fenwick - Carer	

POMPE MINISERVO - POWER CYLINDERS Ø 20/15"		M1	M2
		M3	M4
		<b>Uscita olio - Oil exit</b>	
<b>MS103</b>	Olio freni DOT3-4 - Brake oil DOT3-4		





**POMPE FRENO MINISERVO  
POWER BRAKE CYLINDERS**

ADATTABILI VARI MODELLI  
USED FOR DIFFERENT MODELS

A  
02

**POMPE MINISERVO - POWER CYLINDERS** Ø 20/15"

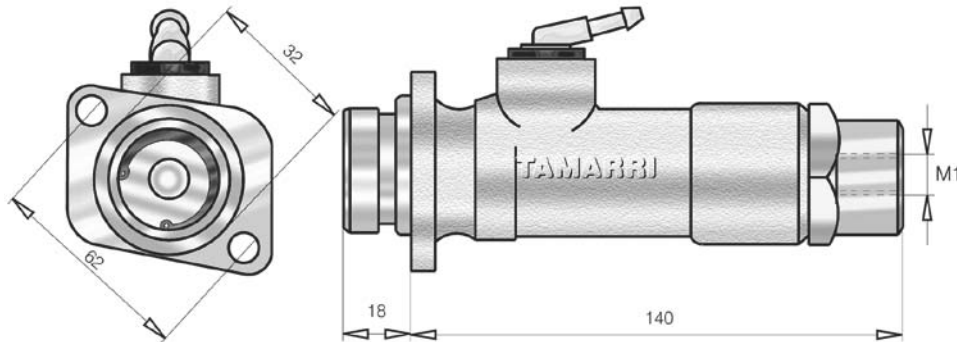

<b>M1</b>	<b>M2</b>
10x1.25 M	
<b>M3</b>	<b>M4</b>
<b>Uscita olio - Oil exit</b>	

**MS100** Olio freni DOT3-4 - Brake oil DOT3-4 Lugli - Robustus

**POMPE MINISERVO - POWER CYLINDERS** Ø 27/35"

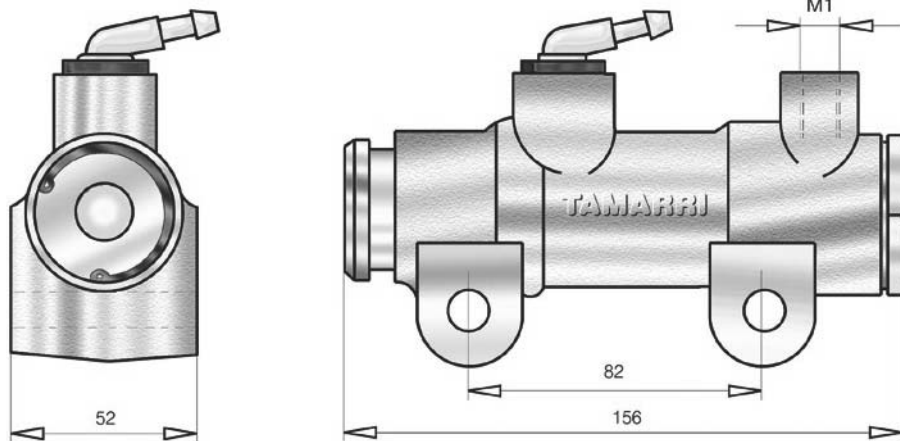

<b>M1</b>	<b>M2</b>
12x1.25 M	
<b>M3</b>	<b>M4</b>
<b>Uscita olio - Oil exit</b>	

**MS104** Olio freni DOT3-4 - Brake oil DOT3-4 OM - Pimespo - Fai - Benfra

**POMPE MINISERVO - POWER CYLINDERS** Ø 30/25"

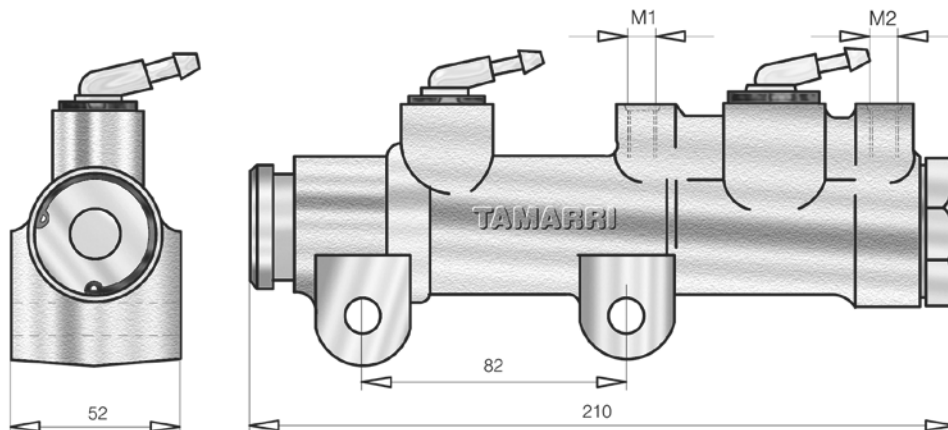

<b>M1</b>	<b>M2</b>
12x1.25 M	12x1.25 M
<b>M3</b>	<b>M4</b>
<b>Uscita olio - Oil exit</b>	

**MS105** Olio freni DOT3-4 - Brake oil DOT3-4



I nostri ricambi non sono originali ma con essi perfettamente intercambiabili  
Our spare parts are not original but with them perfectly interchangeable



**POMPE FRENO MINISERVO  
POWER BRAKE CYLINDERS**

ADATTABILI VARI MODELLI  
USED FOR DIFFERENT MODELS

A  
02

POMPE MINISERVO - POWER CYLINDERS		Ø 1" 1/2 - 38.1	M1	M2
				<p><b>Uscita olio - Oil exit</b></p>

POMPE MINISERVO - POWER CYLINDERS		Ø 1" 3/4 - 44.00	M1	M2
				<p><b>Uscita olio - Oil exit</b></p>

POMPE MINISERVO - POWER CYLINDERS		Ø 1" 1/4 - 31.75	M1	M2
				<p><b>Uscita olio - Oil exit</b></p>



I nostri ricambi non sono originali ma con essi perfettamente intercambiabili  
Our spare parts are not original but with them perfectly interchangeable



**POMPE FRENO MINISERVO  
POWER BRAKE CYLINDERS**

ADATTABILI VARI MODELLI  
USED FOR DIFFERENT MODELS

A  
02

SERVOFRENO AD ARIA COMPLETO - AIR BRAKE BOOSTER ASSY		M1	M2
		M3	M4
		Uscita olio - Oil exit	
<b>MS219</b>	Olio freni DOT3-4 - Brake oil DOT3-4	Clark	

SERVOFRENO AD ARIA - AIR BRAKE BOOSTER		M1	M2
		M3	M4
		Uscita olio - Oil exit	
<b>MS220</b>	Olio freni DOT3-4 - Brake oil DOT3-4	Kalmar	

POMPE MINISERVO - POWER CYLINDERS Ø 1" 1/8 - 28.57 - 38 - 1" 1/2		M1	M2
		M3	M4
		Uscita olio - Oil exit	
<b>MS119</b>	Olio freni DOT3-4 - Brake oil DOT3-4		



I nostri ricambi non sono originali ma con essi perfettamente intercambiabili  
Our spare parts are not original but with them perfectly interchangeable



**POMPE FRENO MINISERVO  
POWER BRAKE CYLINDERS**

ADATTABILI VARI MODELLI  
USED FOR DIFFERENT MODELS

A  
02

SERVOFRENO IDRAULICO - HYDRAULIC BRAKE BOOSTER		M1	M2
		M3	M4
		Uscita olio - Oil exit	
<b>MS96</b>	Servofreno Idraulico - Gola 2x1.5 - Olio Minerale Hydraulic Brake Booster - Relief 2x1.5 - Mineral Oil		Cesab

SERVOFRENO IDRAULICO - HYDRAULIC BRAKE BOOSTER		M1	M2
		M3	M4
		Uscita olio - Oil exit	
<b>MS97</b>	Servofreno Idraulico - Gola 1x1 - Olio Minerale Hydraulic Brake Booster - Relief 1x1 - Mineral Oil		Cesab

SERVOFRENO IDRAULICO - HYDRAULIC BRAKE BOOSTER		M1	M2
		M3	M4
		Uscita olio - Oil exit	
<b>MS98</b>	Servofreno Idraulico - Gola 1x1.4 - Olio Minerale Hydraulic Brake Booster - Relief 1x1.4 - Mineral Oil		Cesab



I nostri ricambi non sono originali ma con essi perfettamente intercambiabili  
Our spare parts are not original but with them perfectly interchangeable



**POMPE FRENO MINISERVO  
POWER BRAKE CYLINDERS**

ADATTABILI VARI MODELLI  
USED FOR DIFFERENT MODELS

A  
02

**SERVOFRENO IDRAULICO - HYDRAULIC BRAKE BOOSTER**

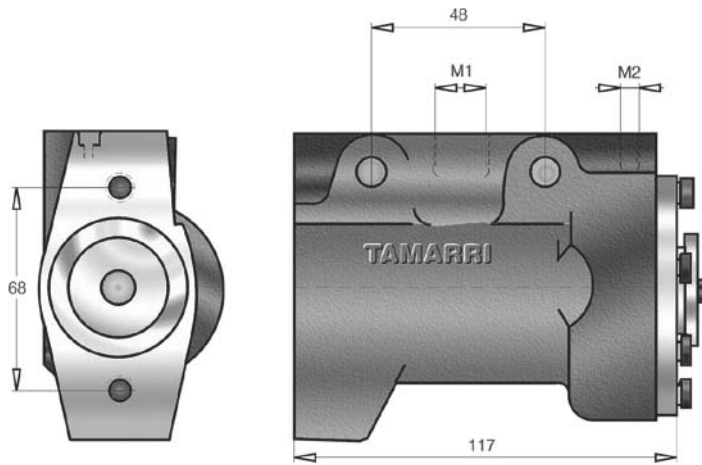

M1	M2
18x1.5 M	14x1.5 M
M3	M4
<b>Uscita olio - Oil exit</b>	

**MS99** Servofreno Idraulico - Gola - Olio Minerale  
Hydraulic Brake Booster - Relief - Mineral Oil  
Cesab

**POMPE MINISERVO - POWER CYLINDERS** Ø 28/20

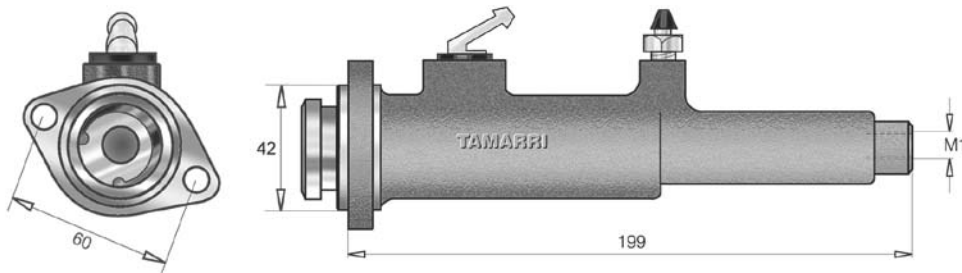

M1	M2
12x1 M	10x1 M
M3	M4
<b>Uscita Olio - Oil exit</b>	

**MS204M** Solo olio minerale - Mineral oil only  
Jungheinrich  
**MS123** Olio freni DOT3-4 - Brake oil DOT3-4  
OM

**POMPE MINISERVO - POWER CYLINDERS** Ø 28/19

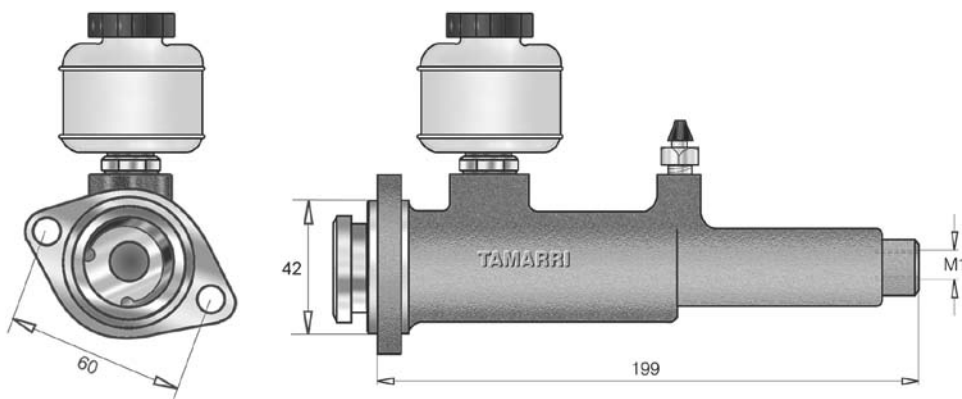

M1	M2
12x1 M	
M3	M4
<b>Uscita olio - Oil exit</b>	

**MS145** Olio freni DOT3-4 - Brake oil DOT3-4  
Steinbok



I nostri ricambi non sono originali ma con essi perfettamente intercambiabili  
Our spare parts are not original but with them perfectly interchangeable



**POMPE FRENO MINISERVO  
POWER BRAKE CYLINDERS**

ADATTABILI VARI MODELLI  
USED FOR DIFFERENT MODELS

A  
02

POMPE MINISERVO - POWER CYLINDERS		Ø 3/4" - 1" 1/4	M1	M2
			M3	M4
			<b>Uscita Olio - Oil exit</b>	
<b>MS124M</b>	Solo olio minerale - Mineral oil only	Caterpillar		
<b>MS124</b>	Olio freni DOT3-4 - Brake oil DOT3-4	Caterpillar		

SERVOFRENO AD ARIA COMPLETO - AIR BRAKE BOOSTER ASSY		M1	M2
		M3	M4
		<b>Uscita olio - Oil exit</b>	
<b>MS127</b>	Con servofreno ad aria - With air servo brake	OM	

SERVOFRENO IDRAULICO - HYDRAULIC BRAKE BOOSTER		Ø 1" - 25.4	M1	M2
			M3	M4
			<b>Uscita olio - Oil exit</b>	
<b>MS129</b>	Solo olio minerale - Mineral oil only	Toyota - Komatsu		







**POMPE FRENO MINISERVO  
POWER BRAKE CYLINDERS**

ADATTABILI VARI MODELLI  
USED FOR DIFFERENT MODELS

A  
02

SERVOFRENO AD ARIA COMPLETO - AIR BRAKE BOOSTER ASSY		M1	M2
			
		M3	M4
		Uscita olio - Oil exit	
<b>MS235</b>	Olio freni DOT3-4 - Brake oil DOT3-4		OM

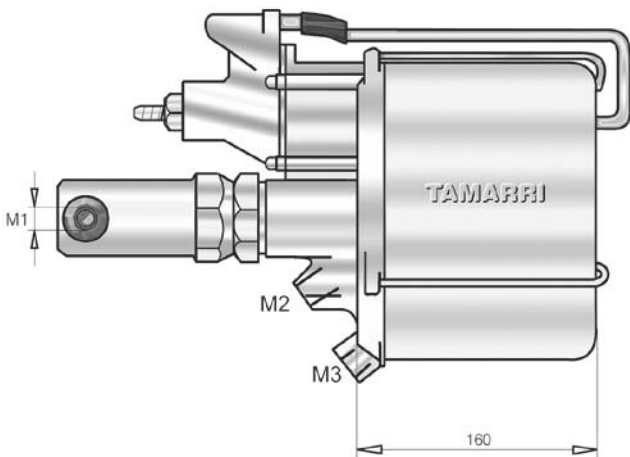
SERVOFRENO AD ARIA COMPLETO - AIR BRAKE BOOSTER ASSY		M1	M2
		12x1.25 M	12x1.25 M
		M3	M4
		Uscita olio - Oil exit	
<b>MS150</b>	Con servofreno ad aria - With air servo brake		OM

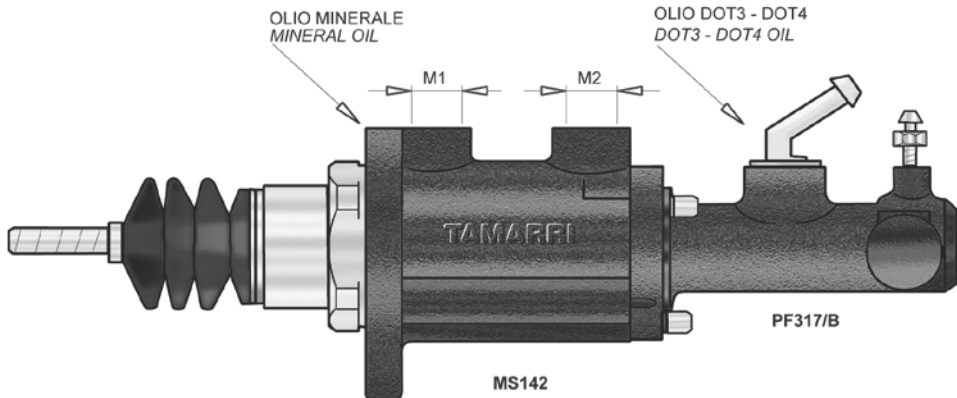
SERVOFRENO IDRAULICO COMPLETO - HYDRAULIC BRAKE BOOSTER Ø 1" - 1/8		M1	M2
		18x1.5 M	18x1.5 M
		M3	M4
		Uscita olio - Oil exit	
<b>MS143</b>	Ms142 servo - Pf317/b pompa Ms142 servo - Pf317/b brake master cyl		Sibicar



I nostri ricambi non sono originali ma con essi perfettamente intercambiabili  
Our spare parts are not original but with them perfectly interchangeable



**POMPE FRENO MINISERVO  
POWER BRAKE CYLINDERS**

ADATTABILI VARI MODELLI  
USED FOR DIFFERENT MODELS

A  
02

**SERVOFRENO IDRAULICO COMPLETO - HYDRAULIC BRAKE BOOSTER**  
Ø 1" - 1/4

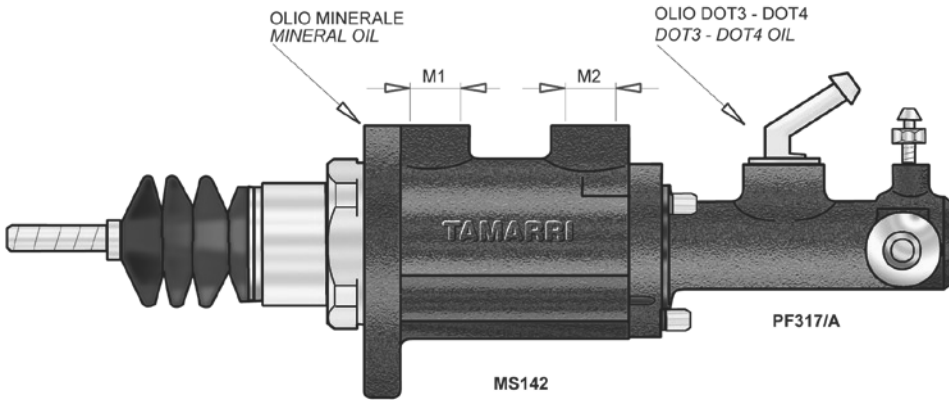

<b>M1</b>	<b>M2</b>
18x1.5 M	18x1.5 M
<b>M3</b>	<b>M4</b>
<b>Uscita olio - Oil exit</b>	

**MS135** Ms142 servo - PF317/A pompa  
Ms142 servo - PF317/A brake master cyl Clark

**SERVOFRENO IDRAULICO COMPLETO - HYDRAULIC BRAKE BOOSTER** Ø 1"

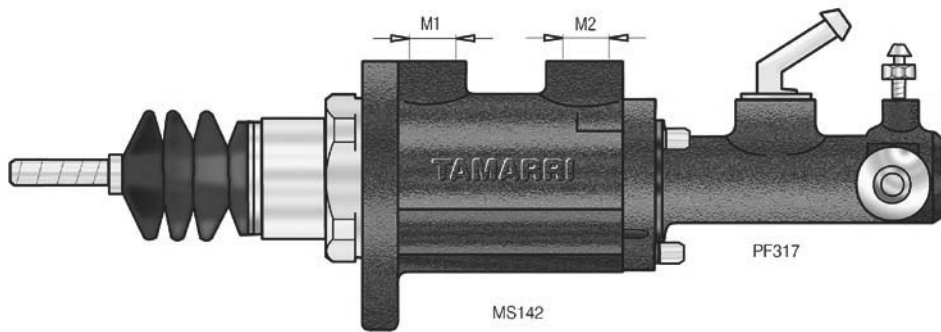

<b>M1</b>	<b>M2</b>
18x1.5 M	18x1.5 M
<b>M3</b>	<b>M4</b>
<b>Uscita olio - Oil exit</b>	

**MS209** Ms142 servo - PF317 pompa  
Ms142 servo - PF317 brake master cyl Hyster

**SERVOFRENO IDRAULICO COMPLETO - HYDRAULIC BRAKE BOOSTER** Ø 20.6

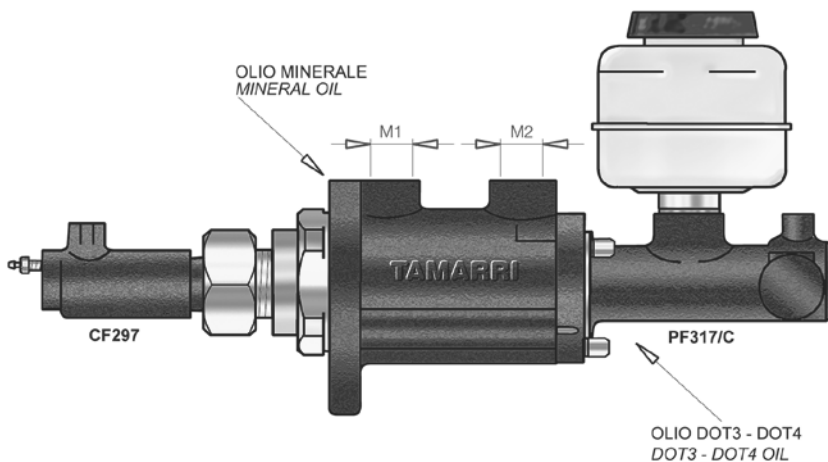

<b>M1</b>	<b>M2</b>
18x1.5 M	18x1.5 M
<b>M3</b>	<b>M4</b>
<b>Uscita olio - Oil exit</b>	

**MS141** Ms142 servo - PF317/C pompa  
Ms142 servo - PF317/C brake master cyl Clark



I nostri ricambi non sono originali ma con essi perfettamente intercambiabili  
Our spare parts are not original but with them perfectly interchangeable



**POMPE FRENO MINISERVO  
POWER BRAKE CYLINDERS**

ADATTABILI VARI MODELLI  
USED FOR DIFFERENT MODELS

A  
02

**SERVOFRENO IDRAULICO COMPLETO - HYDRAULIC BRAKE BOOSTER Ø 1"-1/8**

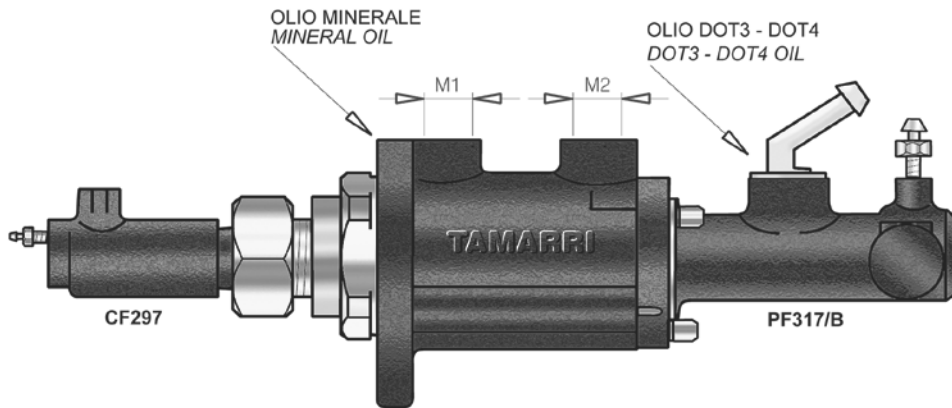

<b>M1</b>	<b>M2</b>
18x1.5 M	18x1.5 M
<b>M3</b>	<b>M4</b>
<b>Uscita olio - Oil exit</b>	

**MS160** Ms142 servo - PF317/B pompa  
Ms142 servo - PF317/B brake master cyl Clark

**SERVOFRENO AD ARIA COMPLETO - AIR BRAKE BOOSTER ASSY**

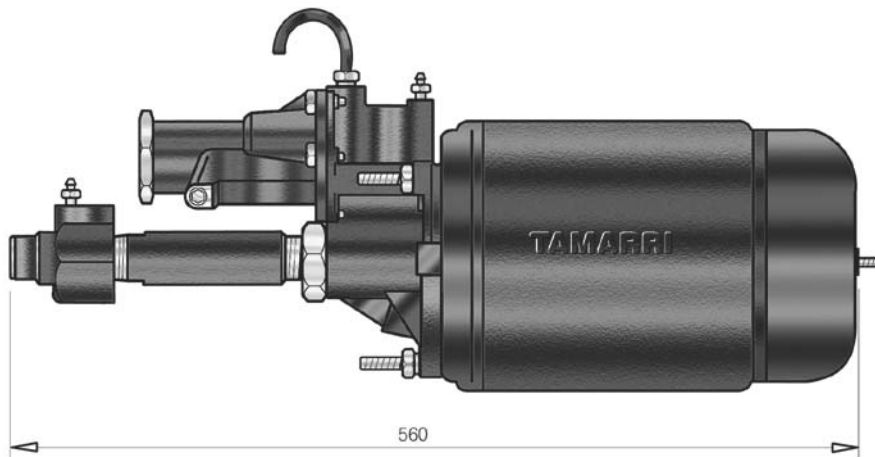

<b>M1</b>	<b>M2</b>
<b>M3</b>	<b>M4</b>
<b>Uscita olio - Oil exit</b>	

**MS156** Con servofreno ad aria - With air servo brake Lancer Boss

**SERVOFRENO AD ARIA COMPLETO - AIR BRAKE BOOSTER ASSY**



<b>M1</b>	<b>M2</b>
3/8" UNF M	3/8" UNF M
<b>M3</b>	<b>M4</b>
<b>Uscita olio - Oil exit</b>	

**MS153** Con servofreno ad aria - With air servo brake Lancer Boss



I nostri ricambi non sono originali ma con essi perfettamente intercambiabili  
Our spare parts are not original but with them perfectly interchangeable



**POMPE FRENO MINISERVO  
POWER BRAKE CYLINDERS**

ADATTABILI VARI MODELLI  
USED FOR DIFFERENT MODELS

A  
02

POMPE MINISERVO - POWER CYLINDERS		Ø 1" 3/4 - 1"			
				<p><b>M1</b></p>	<p><b>M2</b></p>
				<p><b>M3</b></p>	<p><b>M4</b></p>
				<p><b>Uscita olio - Oil exit</b></p>	
<p><b>MS144</b>    Olio freni DOT3-4 - Brake oil DOT3-4</p>					

ERVOFRENO IDRAULICO COMPLETO - HYDRAULIC BRAKE BOOSTER		Ø 1" 3/4 - 1"			
				<p><b>M1</b></p>	<p><b>M2</b></p>
				<p><b>M3</b></p>	<p><b>M4</b></p>
				<p><b>Uscita olio - Oil exit</b></p>	
<p><b>MS158</b>    Servofreno idraulico completo - Servo brake assembly</p>		<p>Linde</p>			

POMPE MINISERVO - POWER CYLINDERS		Ø 1" 1/2			
				<p><b>M1</b></p>	<p><b>M2</b></p>
				<p><b>M3</b></p>	<p><b>M4</b></p>
				<p><b>Uscita olio - Oil exit</b></p>	
<p><b>MS137</b>    Olio freni DOT3-4 - Brake oil DOT3-4</p>		<p>Lancer B. - Coventry C. - Lansing B. - Bationi &amp; Pagani</p>			



I nostri ricambi non sono originali ma con essi perfettamente intercambiabili  
Our spare parts are not original but with them perfectly interchangeable



**POMPE FRENO MINISERVO  
POWER BRAKE CYLINDERS**

ADATTABILI VARI MODELLI  
USED FOR DIFFERENT MODELS

A  
02

POMPE MINISERVO - POWER CYLINDERS Ø 31.75 - 20		M1	M2
		M3	M4
		<b>Uscita Olio - Oil exit</b>	
<b>MS229M</b>	Solo olio minerale - Mineral oil only	OM	

POMPE MINISERVO - POWER CYLINDERS Ø 31.75 - 20		M1	M2
		M3	M4
		<b>Uscita Olio - Oil exit</b>	
<b>MS169M</b>	Solo olio minerale - Mineral oil only		
<b>MS169</b>	Olio freni DOT3-4 - Brake oil DOT3-4		

POMPE MINISERVO - POWER CYLINDERS Ø 27 - 20		M1	M2
		M3	M4
		<b>Uscita Olio - Oil exit</b>	
<b>MS170M</b>	Solo olio minerale - Mineral oil only		
<b>MS170</b>	Olio freni DOT3-4 - Brake oil DOT3-4		





**POMPE FRENO MINISERVO  
POWER BRAKE CYLINDERS**

ADATTABILI VARI MODELLI  
USED FOR DIFFERENT MODELS

A  
02

**POMPE MINISERVO - POWER CYLINDERS** Ø 1" - 7/8"

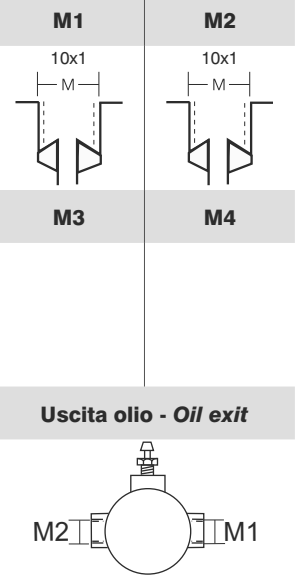
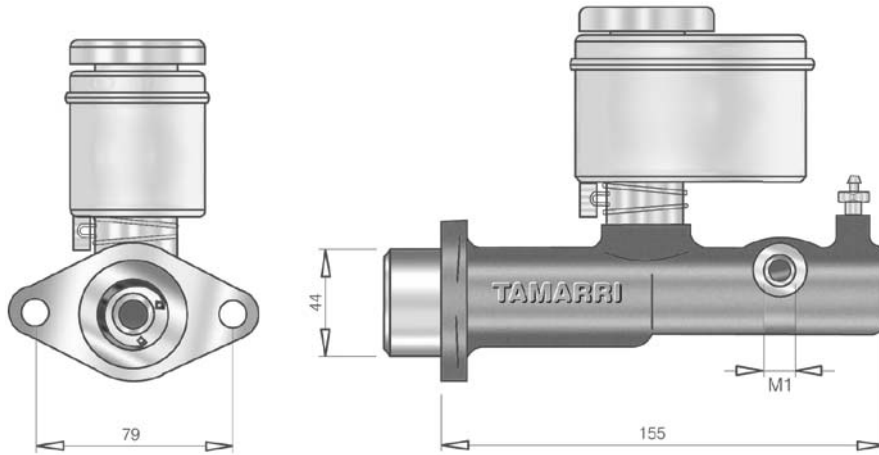

**MS172** Olio freni DOT3-4 - Brake oil DOT3-4

Nissan

**SERVOFRENO AD ARIA COMPLETO - AIR BRAKE BOOSTER ASSY**



**MS174** Servofreno aria - Air brake booster

Hyster

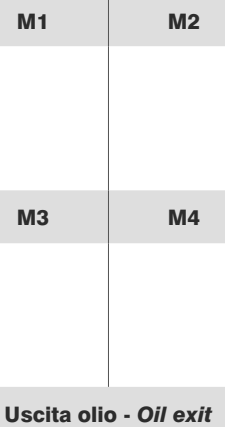

**SERVOFRENO AD ARIA COMPLETO - AIR BRAKE BOOSTER ASSY**

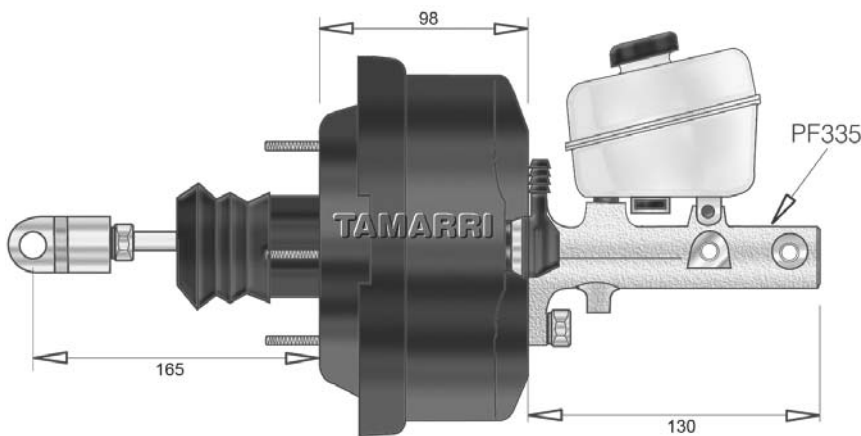

**MS175** Servofreno aria - Air brake booster

Hyster

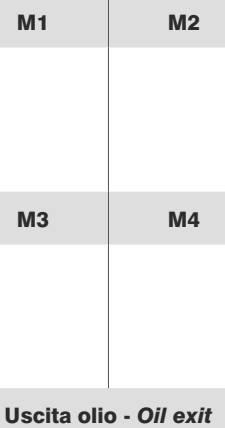

I nostri ricambi non sono originali ma con essi perfettamente intercambiabili  
Our spare parts are not original but with them perfectly interchangeable



**POMPE FRENO MINISERVO  
POWER BRAKE CYLINDERS**

ADATTABILI VARI MODELLI  
USED FOR DIFFERENT MODELS

A  
02

**POMPE MINISERVO - POWER CYLINDERS** Ø 27 - 20

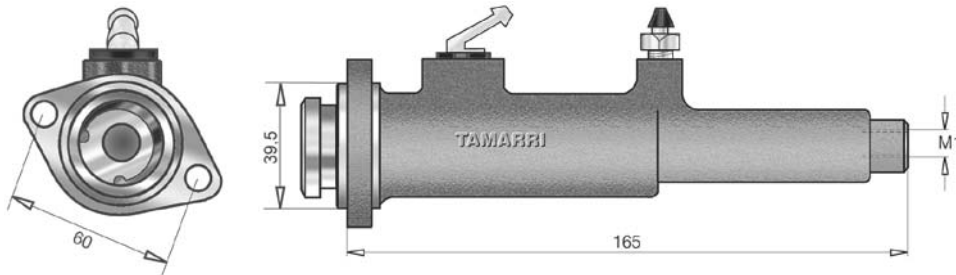

M1	M2
10x1 M	
M3	M4
<b>Uscita Olio - Oil exit</b>	

<b>MS183</b>	Olio freni DOT3-4 - Brake oil DOT3-4	Daewoo
<b>MS183M</b>	Solo olio minerale - Mineral oil only	Daewoo

**SERVOFRENO IDRAULICO - HYDRAULIC BRAKE BOOSTER**

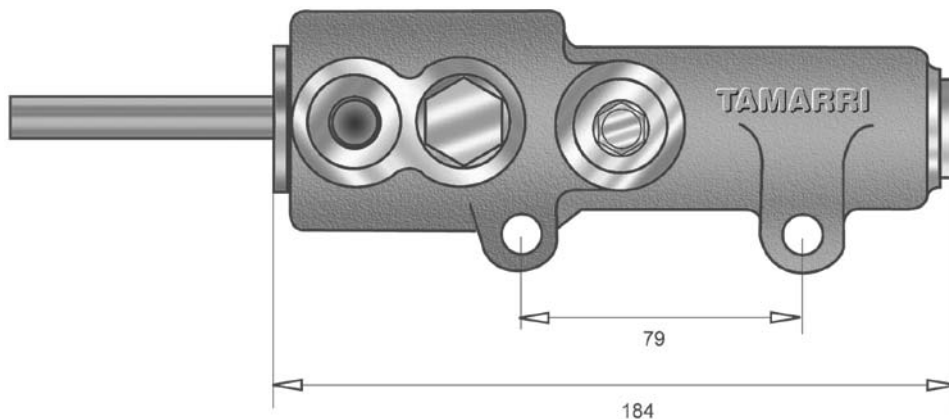

M1	M2
M3	M4
<b>Uscita olio - Oil exit</b>	

<b>MS185</b>	Solo olio minerale - Mineral oil only	Clark
--------------	---------------------------------------	-------

**SERVOFRENO AD ARIA - AIR BOOSTER**

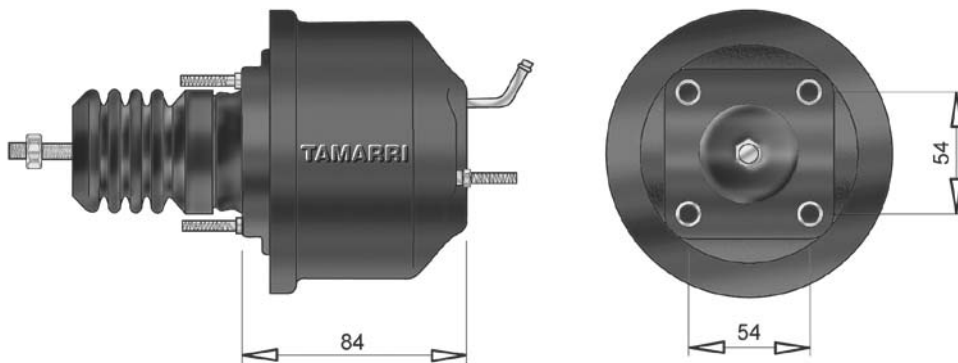

M1	M2
M3	M4
<b>Uscita olio - Oil exit</b>	

<b>MS205</b>	Servofreno aria - Air brake booster	Mitsubishi
--------------	-------------------------------------	------------





**POMPE FRENO MINISERVO  
POWER BRAKE CYLINDERS**

ADATTABILI VARI MODELLI  
USED FOR DIFFERENT MODELS

**A  
02**

SERVOFRENO IDRAULICO 5/8 " - HYDRAULIC BRAKE BOOSTER 5/8"		M1	M2
		M3	M4
		<b>Uscita olio - Oil exit</b>	
<b>MS206</b>	Accoppiata con Ms207 - Coupled with Ms207 Solo olio minerale - Mineral oil only	Toyota	

SERVOFRENO IDRAULICO - HYDRAULIC BRAKE BOOSTER 1"		M1	M2
		M3	M4
		<b>Uscita olio - Oil exit</b>	
<b>MS207</b>	Accoppiata con ms206 - Coupled with ms 206 Solo olio minerale - Mineral oil only	Toyota	

SERVOFRENO IDRAULICO - HYDRAULIC BRAKE BOOSTER		M1	M2
		M3	M4
		<b>Uscita olio - Oil exit</b>	
<b>MS133</b>	Solo olio minerale - Mineral oil only	Daewoo - Komatsu - TCM - Toyota	



I nostri ricambi non sono originali ma con essi perfettamente intercambiabili  
Our spare parts are not original but with them perfectly interchangeable





**POMPE FRENO MINISERVO  
POWER BRAKE CYLINDERS**

ADATTABILI VARI MODELLI  
USED FOR DIFFERENT MODELS

A  
02

SERVOFRENO AD ARIA - AIR BOOSTER		M1	M2
		M3	M4
		Uscita olio - Oil exit	
		<p><b>MS201</b> Accoppiata con pf079 - Coupled with Pf079 Mitsubishi</p>	

POMPE MINISERVO - POWER CYLINDERS Ø 20/15"		M1	M2
		<p>1/8 gas M</p>	<p>10X1,25 M</p>
		<p>10X1,25 M</p>	<p>10X1,25 M</p>
		Uscita olio - Oil exit	
<p><b>MS210</b> Olio freni DOT3-4 - Brake oil DOT3-4 Carer - Fiat</p>			

SERVOFRENO AD ARIA COMPLETO - AIR BRAKE BOOSTER ASSY		M1	M2
		M3	M4
		Uscita olio - Oil exit	
		<p><b>MS217</b> Olio freni DOT3-4 - Brake oil DOT3-4 Hyster</p>	



I nostri ricambi non sono originali ma con essi perfettamente intercambiabili  
Our spare parts are not original but with them perfectly interchangeable





**POMPE FRENO MINISERVO  
POWER BRAKE CYLINDERS**

ADATTABILI VARI MODELLI  
USED FOR DIFFERENT MODELS

A  
02

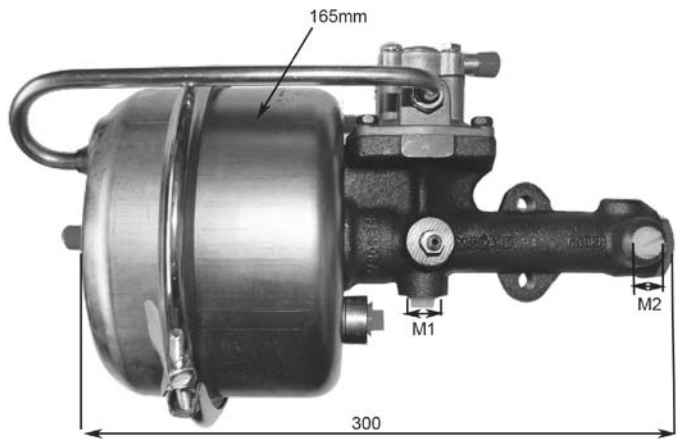
<b>SERVOFRENO AD ARIA - AIR BOOSTER</b> Ø 180x40		<b>M1</b>	<b>M2</b>
		<b>M3</b>	<b>M4</b>
		<b>Uscita olio - Oil exit</b>	
<b>MS218</b>	Accoppiata con Pf108 - <i>Coupled with Pf108</i>	Mitsubishi	

<b>SERVOFRENO AD ARIA COMPLETO - AIR BRAKE BOOSTER ASSY</b>		<b>M1</b>	<b>M2</b>
		1/2" 20 fil. M	1/2" 20 fil. M
		<b>M3</b>	<b>M4</b>
		<b>Uscita olio - Oil exit</b>	
<b>MS222</b>	Olío freni DOT3-4 - <i>Brake oil DOT3-4</i>	Caterpillar	

<b>PEDALIERA FRENO IDRAULICA - HYDRAULIC BRAKE PEDAL</b>		<b>M1</b>	<b>M2</b>
		<b>M3</b>	<b>M4</b>
		<b>Uscita olio - Oil exit</b>	
<b>MS223</b>	Pedaliera pneumatica	Kalmar	



I nostri ricambi non sono originali ma con essi perfettamente intercambiabili  
Our spare parts are not original but with them perfectly interchangeable



**POMPE FRENO MINISERVO  
POWER BRAKE CYLINDERS**

ADATTABILI VARI MODELLI  
USED FOR DIFFERENT MODEL

A  
02

**SERVOFRENO AD ARIA COMPLETO - AIR BRAKE BOOSTER ASSY** Ø 1" 1/2

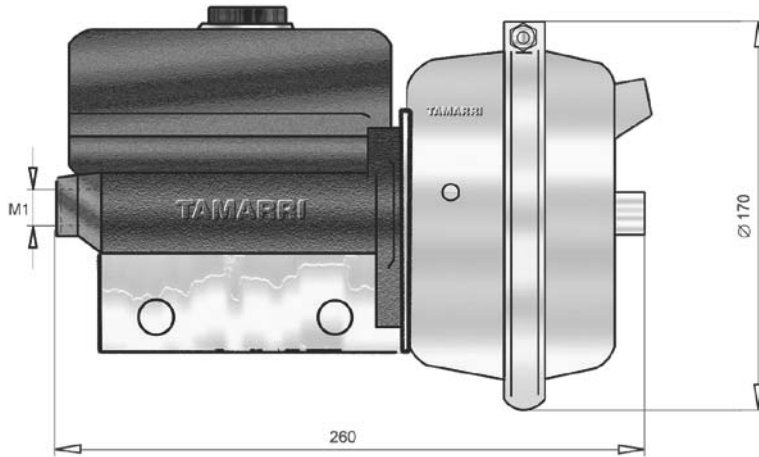

<b>M1</b>	<b>M2</b>
1/2" 20 fil. M	
<b>M3</b>	<b>M4</b>
<b>Uscita olio - Oil exit</b>	

**MS165** Solo pompa freno Pf104 - Only master cylinder pf104 Caterpillar

**VALVOLA FRENO PNEUMATICA - PNEUMATIC BRAKE VALVE**

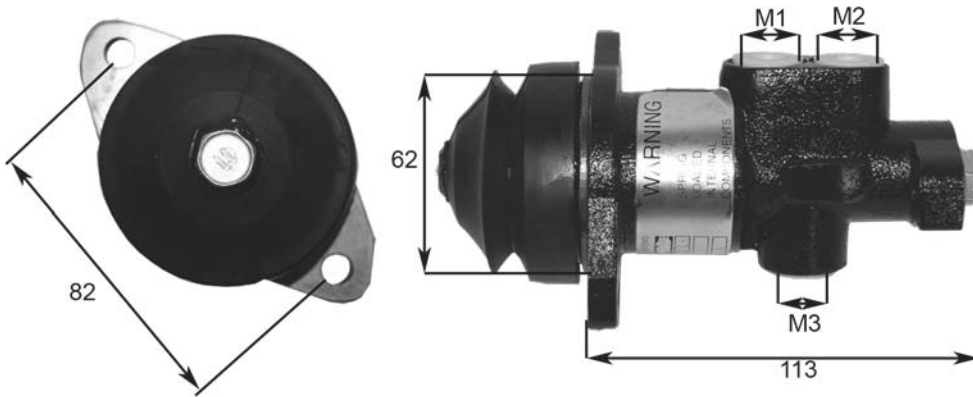

<b>M1</b>	<b>M2</b>
9/16" UNF M	9/16" UNF M
<b>M3</b>	<b>M4</b>
9/16" UNF M	
<b>Uscita olio - Oil exit</b>	

**MS231** Valvola freno pneumatica - Pneumatic brake valve Hyster

**POMPE MINISERVO - POWER CYLINDERS** Ø 1" - 1/2 - 38.1

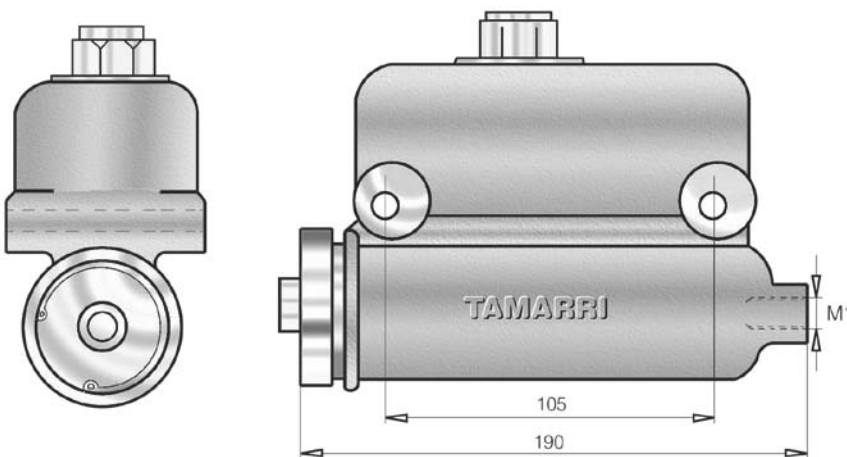

<b>M1</b>	<b>M2</b>
1/2" 20 fil. M	
<b>M3</b>	<b>M4</b>
<b>Uscita olio - Oil exit</b>	

**MS147** Olio freni DOT3-4 - Brake oil DOT3-4 Fiat Allis



I nostri ricambi non sono originali ma con essi perfettamente intercambiabili  
Our spare parts are not original but with them perfectly interchangeable